



MAYEKAWA NORTH AMERICA

MAYEKAWA USA OFFICES

Katy

29875 Medline Ln
Katy, TX 77494
832-975-0975

Seattle

2615 W. Casino Rd., Unit 6F
Everett, WA 98204
425-645-9400

York

3395 Farmtrail Rd.
York, PA 17406
717-779-0138

West Nyack

250 West Nyack Rd., Suite 250
West Nyack, NY 10994
914-301-9770

Torrance

19240 Van Ness Ave.
Torrance, CA 90501
310-328-1362

MAYEKAWA CANADA OFFICES

Vancouver

4-1595 Cliveden Ave
Delta, BC V3M 6M2
604-270-1544

Calgary

2216 Pegasus Way NE
Calgary, AB T2E 8M5
403-250-1554

Toronto

Unit #1, 1745 Bonhill Road
Mississauga, ON L5T 1C1
905-564-0664

MYCOM

Products Handbook

Screw & Reciprocating Compressors, Control
Panels, Oil Pumps, and OEM Parts

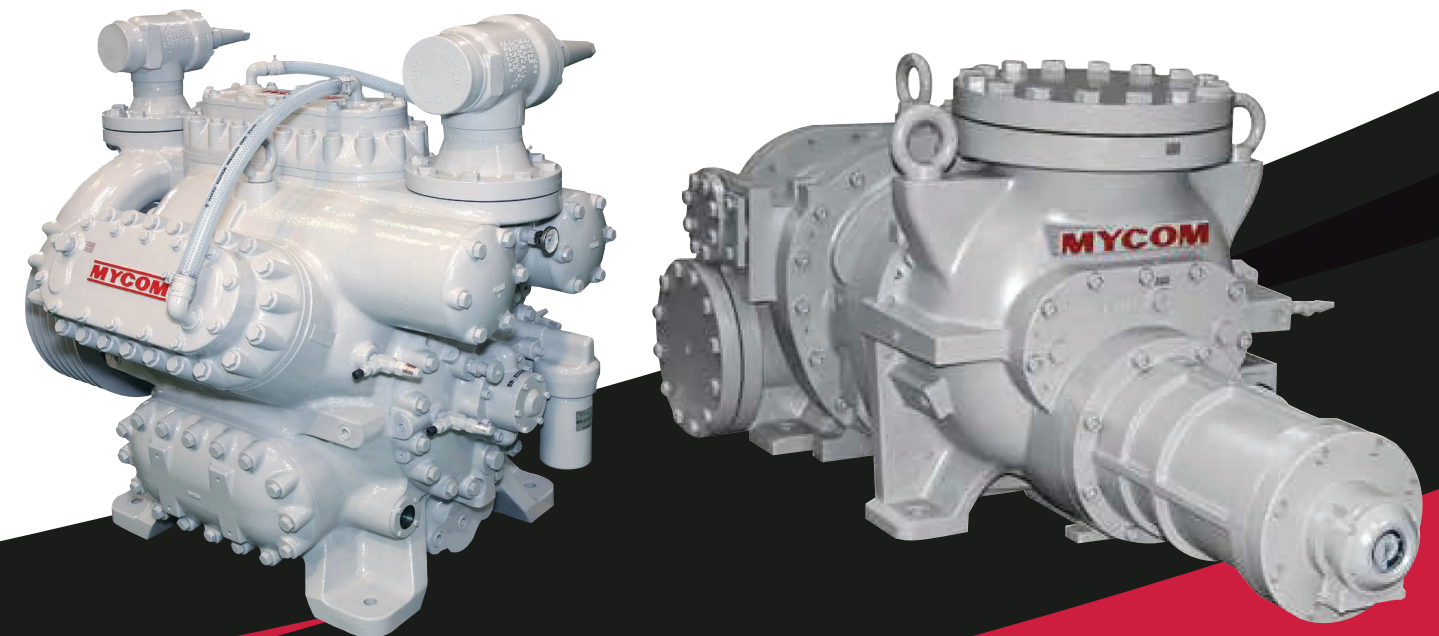

MAYEKAWA USA, INC.
<https://mayekawa.com/americas/mna>

Tel: +1 (615) 773-2859
24 Hr Service: +1 (800) 836-9266
Email: info@mayekawausa.com

MAYEKAWA CANADA, INC.
<https://mayekawa.com/americas/mna>

Vancouver: +1 (604) 270-1544
Calgary: +1 (403) 250-1554
Toronto: +1 (905) 564-0664

MYCOM

TABLE OF CONTENTS

About Mayekawa	1
Vision	2
Sales Reps	3-4
Screw Compressors	5-6
J-series	7-8
V-series	9-10
C-series	11-12
i-series	13-14
UD-series	15-16
MHS-series	17-18
MYPRO TOUCH+	19-20
Reciprocating Compressors	21-22
M-series	23-24
K-series	25-26
HK-series	27-28
HS-series	29-30
WBHE-series	31-32
WA-series	33-34
L-series	35-36
MYCORE-RC 100	37-38
Oil Pumps	39-40
MP & FP Oil Pumps	41-42
OEM Parts	43-44

ABOUT MAYEKAWA

Mayekawa Manufacturing Company has expanded its business by focusing on freezing and compression technologies ever since its establishment in 1924. As a thermal engineering company we have long contributed to providing business solutions to our customers based on these technologies and in turn continuously evolve our products and services. Mayekawa is an industry leader in the manufacturing of MYCOM industrial refrigeration compressors and specialty equipment offering unprecedented levels of energy efficient savings solutions. Mayekawa's name has been synonymous for reliability, quality and innovation globally. Today, we have locations in more than 32 countries.

Mayekawa has been manufacturing compressors since 1924 in Japan and 1967 in the United States. Mayekawa USA has been involved in the design and manufacturing of state-of-the-art screw and reciprocating compressor packages for commercial and industrial applications throughout the world.

“ MYCOM compressors deliver energy efficient, low maintenance and cost effective solutions. ”

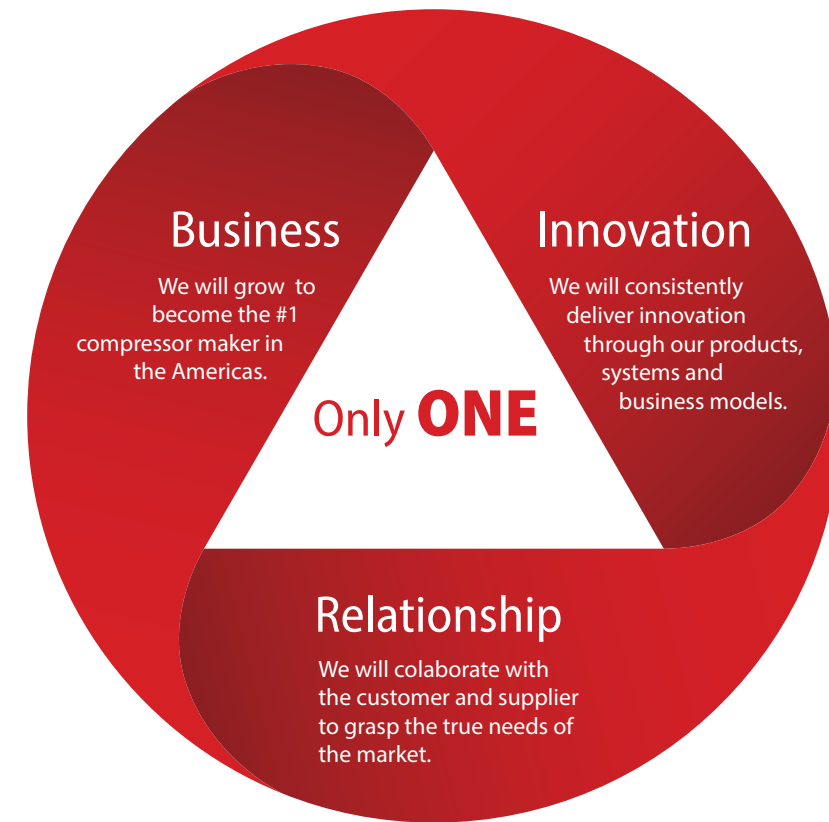

VISION

Mayekawa strives to focus on growing its business to become the #1 compressor maker in the Americas by delivering innovative solutions and a strong relationship with its customers and suppliers. Through this method, Mayekawa strives to become the “Only ONE” choice in the industry.

SALES REPS

USA SALES REP OFFICES

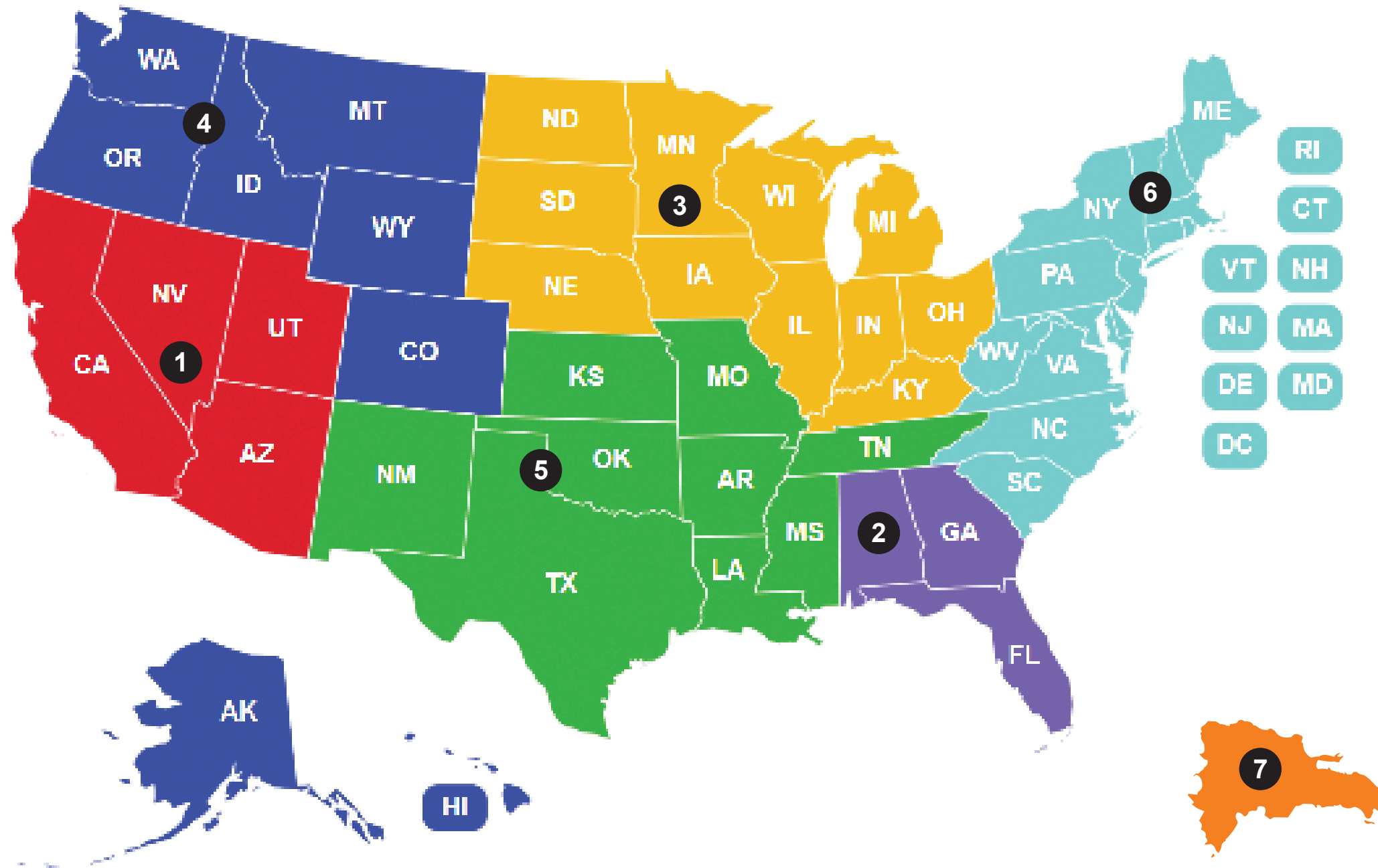

- 1 Clark Johnson Company, Inc.**
 14747 Artesia Blvd, 2-E
 La mirada, CA 90638
 714-521-6161
- 2 Freeze-Pro, Inc.**
 3516 Enterprise Way, Suite 3
 Green Cover Springs, FL 32043
 904-531-5065
- 3 Stanton & Associates, Inc.**
 6910 N. Main Street, Unit 15
 Granger, IN 46530
 574-247-5522
- 4 IREP**
 1540 NE 95th Street
 Seattle, WA 98115
 206-941-8095 or 604-219-6049
- 5 Industrial Refrigeration Sales, LLC.**
 8000 Fair Oaks Pkwy, Suite 3117
 Boerne, TX 78015
 210-314-8733
- 6 Refrigeration Technology Solutions**
 PO Box 38145
 Albany, NY 12203
 803-717-2717
- 7 Refrielectrica Popa, S.R.L.**
 C/ Rubén Dario No. 25, Ens. Enriquillo
 Herrera, Santo Domingo Oeste, R.D.
 809-271-5507

SCREW COMPRESSORS

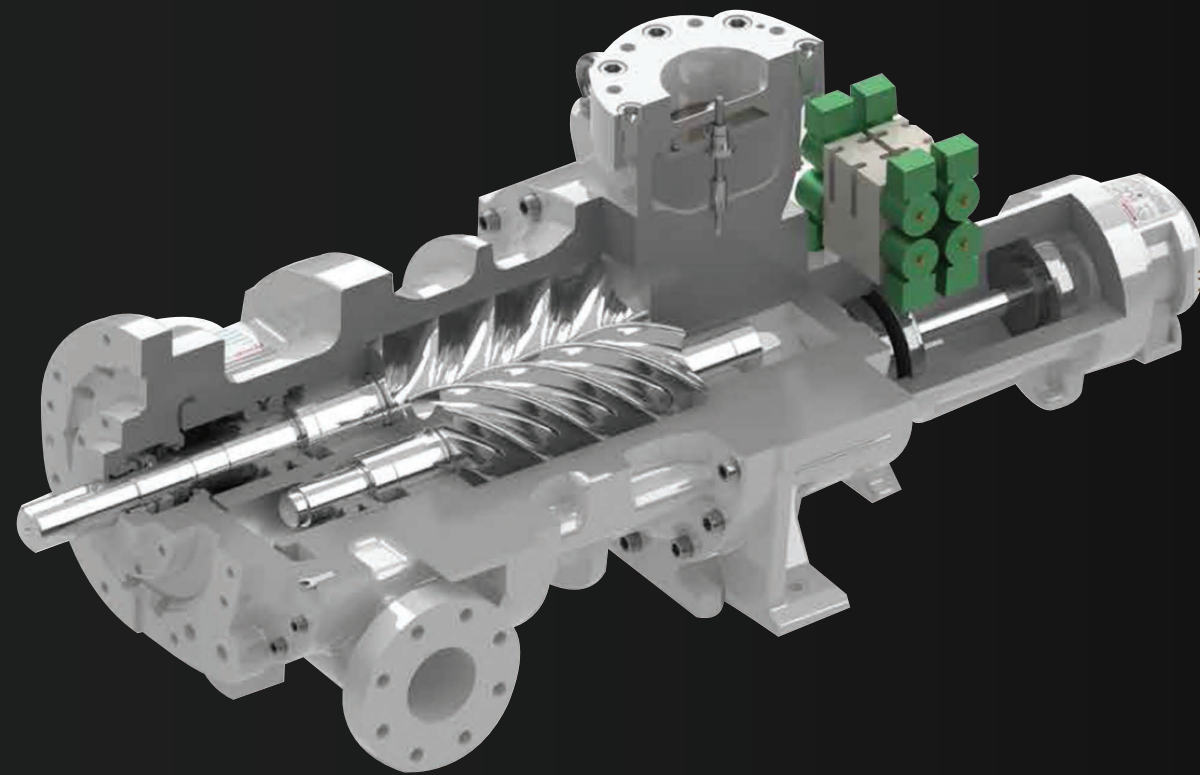

- J-series
- V-series
- C-series
- i-series
- UD-series
- MHS-series

Mayekawa started manufacturing MYCOM Screw Compressors in 1964. Since then, Mayekawa has achieved to produce high-performance and high-efficiency compressors by developing its own manufacturing skills and rotor lobe designs. Mayekawa's screw compressors are designed for durability, low-noise and low-vibration to offer packaged solutions.

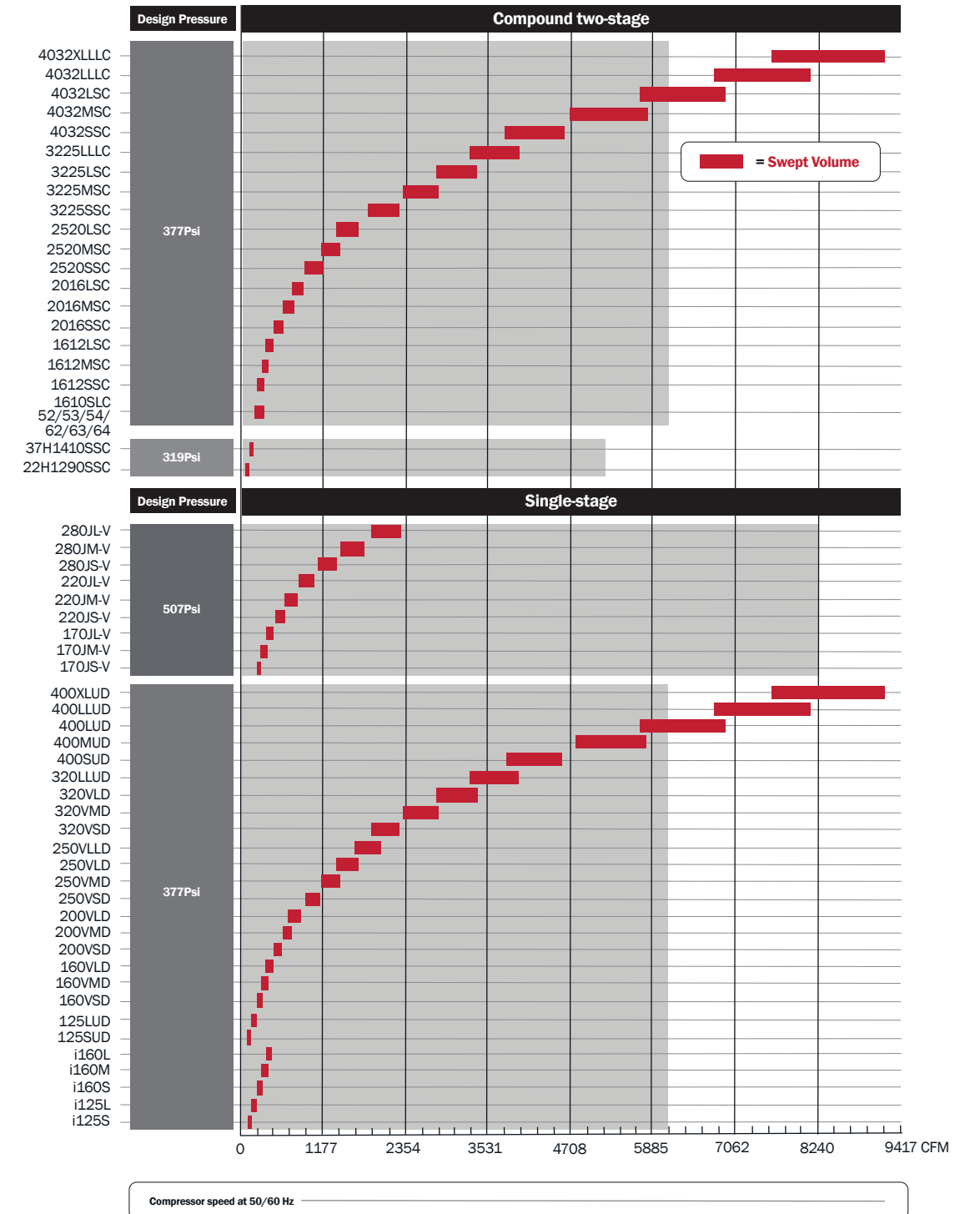

J-SERIES

Screw Compressor [Single Stage] Open Type



High Performance Derived from New Design

The series is intended to be the standard for next-generation compressors in industrial fields.

Adoption of New-Type Rotor

The newly developed J-profile rotor design, consisting of a 5:6 lobe configuration, enables to achieving high-performance.

Rich in Variation

Natural refrigerants (e.g. ammonia, CO₂, propane) and fluorocarbon refrigerants can be used. Flexible setup of applications is possible.

Low Vibration and Low Noise

Noise level reduced by 5 dB compared to a conventional machine type.

Stepless Capacity Control from 100% to 25% Range

Due to the stepless control feature, the series optimally operates in accordance with the required load and delivers high energy-saving performance.

Automatically Variable Vi Mechanism (2.5-5.0 range) to Efficiently Cover Wide Temperature Range

Supports Flange Motors to Facilitate Design of Packaged Systems

The built-in check valve as well as the compatibility with flange motors help reduce cost for designing packaged systems while contributing to space saving.

* The 280J has no built-in check valve and thus does not support flange motors.

Specifications

Item	Model (N/C/P/F) ¹		170J			220J			280J		
	S-V	M-V	L-V	S-V	M-V	L-V	S-V	M-V	L-V		
Refrigerant	Ammonia / CO ₂ / Propane, Propylene / HFCs										
Theoretical displacement	2950rpm	CFM	230	298	388	504	656	852	1110	1443	1878
	3550rpm	CFM	276	359	467	606	789	1025	1335	1736	2260
Theoretical displacement	2950rpm	m ³ /h	390	507	659	856	1114	1447	1886	2451	3190
	3550rpm	m ³ /h	469	610	793	1030	1340	1741	2269	2949	3839
Minimum rotation speed	rpm	1450 ²									
Maximum rotation speed	rpm	4500 ²									
Rotation direction	CCW as viewed from motor										
Capacity control	%	25-100						30-100			
Gas inlet port	ANSI #300 5"			ANSI #300 8"			ANSI #300 12"				
Gas outlet port	ANSI #300 3"			ANSI #300 5"			ANSI #300 8"				
Flange motor connection	NEMA	44*D / 50*D			44*D / 50*D			Not compatible			
	IEC	FF500 / 600			FF500 / 600						

* 1. Specify the refrigerant by adding a prefix to the model code (N = ammonia / C = CO₂ / P = propane, propylene / F = fluorocarbons).

* 2. The range of rotation speed varies by operating conditions. Please refer to the ranges of use stated in the operating instructions.

Performance charts

Refrigerant	Temperature condition	Ammonia		CO ₂		Propane		R404A			R134a				
		-40/+35°C • -40/+95°F	-10/+35°C • +14/+95°F	-50/+10°C • -58/+14°F	-10/+35°C • +14/+95°F	-40/+35°C • -40/+95°F	0/+40°C • +32/+104°F	+2/+42°C • +36/+108°F							
Model	Liquid Subcooling: 5°C/ 9°F	Liquid Subcooling: 5°C/ 0°F		Liquid Subcooling: 0°C/ 0°F		Liquid Subcooling: 5°C/ 9°F		Liquid Subcooling: 5°C/ 9°F			Liquid Subcooling: 5°C/ 9°F				
	Suction Superheat: 0°C/0°F	Suction Superheat: 0°C/0°F		Suction Superheat: 0°C/0°F		Suction Superheat: 10°C/18°F		Suction Superheat: 25°C/45°F			Suction Superheat: 25°C/45°F				
	Rotation speed: 2950rpm	Rotation speed: 2950rpm		Rotation speed: 2950rpm		Rotation speed: 2950rpm		Rotation speed: 2950rpm			Rotation speed: 2950rpm				
	Economizer-type					Economizer-type									
170JS-V	Cooling Capacity	21.2RT	74.5kW	73.5RT	258.7kW	118.5RT	416.7kW	58.6RT	206.2kW	24.6RT	86.7kW	85.5RT	300.9kW	58.5RT	206.7kW
	Absorbed Power	67.5HP	50.3kW	88.1HP	65.7kW	187.2HP	139.6kW	78.4HP	58.5kW	86.4HP	64.4kW	119.1HP	88.8kW	66.2HP	49.4kW
170JM-V	Cooling Capacity	27.4RT	96.4kW	95.5RT	335.8kW	153.7RT	540.7kW	76.1RT	267.6kW	31.1RT	109.3kW	111.0RT	390.5kW	76.2RT	268.2kW
	Absorbed Power	85.0HP	63.4kW	113.9HP	84.9kW	245.3HP	182.9kW	101.5HP	75.7kW	107.7HP	80.3kW	152.1HP	113.4kW	84.25HP	63.0kW
170JL-V	Cooling Capacity	35.8RT	125.9kW	124.4RT	437.5kW	200.2RT	704.3kW	99.1RT	348.5kW	39.3RT	138.1kW	144.6RT	508.7kW	99.3RT	349.4kW
	Absorbed Power	108.8HP	81.1kW	146.3HP	109.1kW	317.4HP	236.7kW	130.6HP	97.4kW	135.3HP	100.9kW	195.5HP	145.8kW	108.4HP	80.8kW
220JS-V	Cooling Capacity	50.4RT	177.3kW	169.2RT	595.3kW	280.8RT	987.7kW	137.2RT	482.7kW	55.8RT	196.4kW	186.7RT	656.7kW	128.6RT	452.5kW
	Absorbed Power	156.0HP	116.3kW	204.0HP	152.1kW	447.4HP	333.6kW	180.2HP	134.4kW	207.7HP	154.9kW	285.5HP	212.9kW	155.8HP	116.2kW
220JM-V	Cooling Capacity	65.5RT	230.3kW	219.6RT	772.3kW	364.1RT	1280.8kW	177.9RT	625.9kW	72.6RT	255.2kW	242.2RT	851.8kW	166.8RT	586.8kW
	Absorbed Power	197.4HP	147.2kW	258.3HP	192.6kW	569.8HP	424.9kW	227.8HP	169.9kW	266.3HP	198.6kW	367.4HP	274.0kW	199.3HP	148.6kW
220JL-V	Cooling Capacity	85.7RT	301.4kW	286.9RT	1009.3kW	475.7RT	1673.1kW	232.4RT	817.6kW	95.0RT	334.2kW	316.5RT	1113.2kW	218.0RT	766.7kW
	Absorbed Power	254.1HP	189.5kW	330.6HP	246.5kW	729.9HP	544.3kW	290.2HP	216.4kW	349.9HP	260.9kW	483.4HP	360.5kW	258.9HP	193.1kW
280JS-V	Cooling Capacity	119.3RT	419.5kW	386.4RT	1359.0kW	636.1RT	2237.4kW	303.0RT	1065.7kW	132.1RT	464.8kW	431.4RT	1517.3kW	290.0RT	1020.0kW
	Absorbed Power	340.9HP	254.2kW	442.7HP	330.1kW	972.8HP	725.4kW	392.5HP	292.7kW	457.5HP	341.2kW	625.3HP	466.3kW	343.2HP	255.9kW
280JM-V	Cooling Capacity	154.7RT	544.1kW	500.8RT	1761.6kW	824.6RT	2900.3kW	392.8RT	1381.5kW	171.4RT	602.9kW	559.2RT	1967.0kW	376.0RT	1322.4kW
	Absorbed Power	425.2HP	317.1kW	554.6HP	413.6kW	1232.0HP	918.7kW	493.6HP	368.1kW	576.4HP	429.8kW	792.1HP	590.7kW	435.3HP	324.6kW
280JL-V	Cooling Capacity	201.6RT	709.0kW	652.1RT	2293.7kW	1073.6RT	3776.2kW	511.4RT	1798.7kW	223.3RT	785.4kW	728.2RT	2561.3kW	489.5RT	1721.8kW
	Absorbed Power	532.8HP	397.3kW	696.5HP	519.4kW	1559.4HP	1162.9kW	622.1HP	463.9kW	732.9HP	546.5kW	1011.8HP	754.5kW	556.8HP	415.2kW

* Please consult us for further details.

Outer dimensions

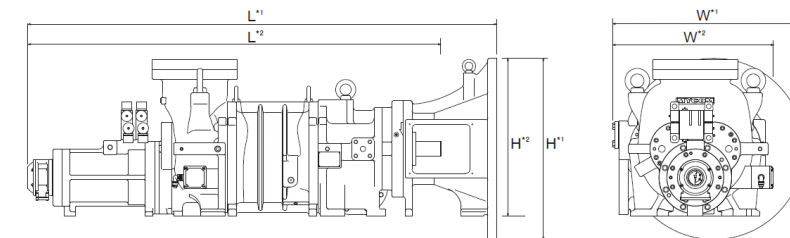

Model	Weight	W	L	H
170JS-V*1	1929lb/875kg	26"/669mm	63"/1599mm	26"/660mm
170JM-V*1	1995lb/905kg	26"/669mm	65"/1654mm	26"/660mm
170JL-V*1	2094lb/950kg	26"/669mm	68"/1726mm	26"/660mm
220JS-V*1	3307lb/1500kg	34"/859mm	76"/1935mm	32"/810mm
220JM-V*1	3439lb/1560kg	34"/859mm	79"/2007mm	32"/810mm
220JL-V*1	3594lb/1630kg	34"/859mm	83"/2100mm	32"/810mm
280JS-V*2	5071lb/2300kg	35"/896mm	83"/2112mm	32"/812mm
280JM-V*2	5401lb/2450kg	35"/896mm	87"/2205mm	32"/812mm
280JL-V*2	5732lb/2600kg	35"/896mm	92"/2328mm	32"/812mm

* The outer dimension drawings illustrate the model 220JL with an IEC FF600 motor spacer.

* 1. Models 170-220JS/JM/JL include an IEC FF600 flange motor connection. * 2. Models 280JS/JM/JL do not support flange motor spacers.

* Please consult us for further details.

V-SERIES

Screw Compressor [Single Stage] Open Type



Variable Vi Mechanism (2.63-5.80 range) to Efficiently Cover a Wide Temperature Range

Offers a Wide Range of Capacities

Available in 13 models, the V-series covers a wide displacement range from 244CFM to 2790CFM (415 m³/h to 4740 m³/h).

* At 2950 rpm

Applications

Operates over a wide range of temperature and serves in industrial refrigeration, freezing and air conditioning applications. Also workable as a booster compressor.

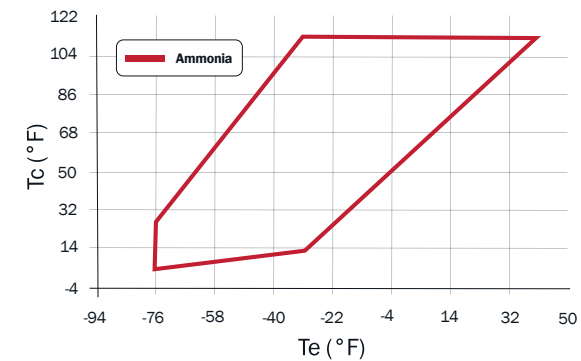

* The temperature range varies by model.

Longtime Seller

With a proven 4:6 rotor configuration, the V-series offers optimal performance to customers.

Specifications

Item	Model (N/P/F) ^{*1,2}		160V			200V			250V				320V		
			SD	MD	LD	SD	MD	LD	SD	MD	LD	LLD	SD	MD	LD
Refrigerant	Ammonia / Propane, Propylene / HFCs														
Theoretical displacement	2950rpm	CFM	244	305	366	477	600	712	930	1165	1389	1648	1866	2331	2790
	3550rpm	CFM	294	367	441	574	718	859	1118	1401	1672	1984	2248	2802	3355
Theoretical displacement	2950rpm	m ³ /h	415	519	622	810	1020	1210	1580	1980	2360	2800	3170	3960	4740
	3550rpm	m ³ /h	499	624	749	975	1220	1460	1900	2380	2840	3370	3820	4760	5700
Minimum rotation speed	rpm	1450 ^{*3}													
Maximum rotation speed	rpm	4500 ^{*3}													
Rotation direction	CCW as viewed from motor														
Capacity control	%	30-100													
Gas inlet port	MYCOM 125A ^{*4}			MYCOM 150A ^{*4}			MYCOM 250A ^{*4}				MYCOM 350A ^{*4}				
Gas outlet port	MYCOM 100CD ^{*4}			MYCOM 125CD ^{*4}			MYCOM 150CD ^{*4}				MYCOM 200CD ^{*4}				

* 1. Specify the refrigerant by adding a prefix to the model code (N = ammonia / P = propane, propylene / F = fluorocarbons).

* 2. Please contact us separately for models with a designation ending with G (downward discharge).

* 3. The range of rotation speed varies by operating conditions. Please refer to the ranges of use stated in the operating instructions.

* 4. Flanges with a designation starting with MYCOM are in-house products of MYCOM.

Performance charts

Refrigerant	Temperature condition	Ammonia					Propane		R404A				R134a		
		-40/+35°C • -40/+95°F	-40/-10°C • -40/+14°F	-10/+35°C • +14/+95°F	-10/+35°C • +14/+95°F	-40/+35°C • -40/+95°F	0/+40°C • +32/+104°F	+2/+42°C • +36/+108°F	Liquid Subcooling: 5°C/9°F	Liquid Subcooling: 5°C/9°F	Liquid Subcooling: 5°C/9°F	Liquid Subcooling: 5°C/9°F	Liquid Subcooling: 5°C/9°F	Liquid Subcooling: 5°C/9°F	
Model		Liquid Subcooling: 5°C/9°F Suction Superheat: 0°C/0°F Rotation speed: 2950rpm Economizer-type					Liquid Subcooling: 5°C/9°F Suction Superheat: 0°C/0°F Rotation speed: 2950rpm		Liquid Subcooling: 5°C/9°F Suction Superheat: 5°C/45°F Rotation speed: 2950rpm		Liquid Subcooling: 5°C/9°F Suction Superheat: 25°C/45°F Rotation speed: 2950rpm		Liquid Subcooling: 5°C/9°F Suction Superheat: 25°C/45°F Rotation speed: 2950rpm		
		Rotation speed: 2950rpm					Rotation speed: 2950rpm		Rotation speed: 2950rpm		Rotation speed: 2950rpm		Rotation speed: 2950rpm		
160VSD/G	Cooling Capacity	21.4RT	75.2kW	23.7RT	83.4kW	77.6RT	272.9kW	62.5RT	219.9kW	25.3RT	89.0kW	94.9RT	333.9kW	62.1RT	218.6kW
	Absorbed Power	71.6HP	53.4kW	27.0HP	20.1kW	99.6HP	74.3kW	91.6HP	68.3kW	97.2HP	72.5kW	132.5HP	98.8kW	75.0HP	55.9kW
160VMD/G	Cooling Capacity	26.7RT	94.0kW	30.0RT	105.4kW	97.1RT	341.6kW	78.4RT	275.8kW	31.5RT	110.9kW	119.0RT	418.5kW	78.4RT	275.6kW
	Absorbed Power	86.5HP	64.5kW	33.0HP	24.6kW	120.0HP	89.5kW	110.4HP	82.3kW	117.1HP	87.3kW	159.6HP	119.0kW	92.0HP	68.6kW
160VLD/G	Cooling Capacity	32.0RT	112.6kW	36.2RT	127.5kW	116.4RT	409.4kW	94.1RT	331.1kW	37.9RT	133.2kW	142.8RT	502.4kW	94.6RT	332.8kW
	Absorbed Power	102.7HP	76.6kW	39.6HP	29.5kW	142.5HP	106.3kW	131.0HP	97.7kW	138.8HP	103.5kW	189.6HP	141.4kW	110.4HP	82.3kW
200VSD/G	Cooling Capacity	42.5RT	149.6kW	48.8RT	171.6kW	153.3RT	539.8kW	122.9RT	432.2kW	50.7RT	178.4kW	186.4RT	655.6kW	125.1RT	439.9kW
	Absorbed Power	138.9HP	103.6kW	52.6HP	39.2kW	192.8HP	143.8kW	177.3HP	132.2kW	188.8HP	140.8kW	256.4HP	191.2kW	146.4HP	109.2kW
200VMD/G	Cooling Capacity	53.9RT	189.5kW	61.5RT	216.2kW	194.2RT	683.1kW	155.2RT	546.0kW	63.4RT	223.0kW	235.4RT	828.1kW	158.7RT	558.2kW
	Absorbed Power	169.5HP	126.4kW	65.3HP	48.7kW	234.8HP	175.1kW	216.0HP	161.1kW	229.6HP	171.2kW	312.5HP	233.0kW	181.8HP	135.6kW
200VLD/G	Cooling Capacity	65.2RT	229.4kW	73.9RT	260.0kW	234.6RT	825.3kW	187.2RT	658.5kW	76.1RT	267.8kW	283.9RT	998.6kW	189.6RT	667.0kW
	Absorbed Power	201.2HP	150.0kW	77.5HP	57.8kW	278.5HP	207.7kW	256.1HP	191.0kW	272.0HP	202.8kW	370.5HP	276.3kW	215.8HP	160.9kW
250VSD/G	Cooling Capacity	86.1RT	302.7kW	96.7RT	340.0kW	305.3RT	1073.7kW	244.8RT	860.9kW	102.1RT	359.0kW	371.1RT	1305.3kW	248.3RT	873.2kW
	Absorbed Power	264.3HP	197.1kW	102.5HP	76.4kW	365.0HP	272.2kW	335.7HP	250.3kW	359.5HP	268.1kW	485.6HP	362.1kW	285.5HP	212.9kW
250VMD/G	Cooling Capacity	108.3RT	380.8kW	121.8RT	428.4kW	383.5RT	1349.1kW	308.3RT	1084.4kW	127.2RT	447.4kW	467.3RT	1643.8kW	311.1RT	1094.3kW
	Absorbed Power	325.3HP	242.6kW	126.1HP	94.0kW	449.1HP	334.9kW	412.9HP	307.9kW	440.8HP	328.7kW	597.3HP	445.4kW	351.2HP	261.9kW
250VLD/G	Cooling Capacity	129.7RT	456.1kW	145.8RT	513.0kW	458.1RT	1611.5kW	369.2RT	1298.5kW	151.6RT	533.4kW	559.5RT	1968.1kW	370.8RT	1304.3kW
	Absorbed Power	387.8HP	289.2kW	150.5HP	112.2kW	535.6HP	399.4kW	492.5HP	367.3kW	524.5HP	391.1kW	712.6HP	531.4kW	418.9HP	312.4kW
250VLLD	Cooling Capacity	152.5RT	536.4kW	172.5RT	606.9kW	542.0RT	1906.4kW	436.7RT	1536.0kW	186.4RT	655.7kW	768.3RT	2702.3kW	440.0RT	1547.5kW
	Absorbed Power	457.3HP	341.0kW	178.0HP	132.7kW	633.6HP	472.5kW	582.8HP	434.6kW	567.5HP	423.2kW	687.0HP	512.3kW	495.6HP	369.6kW
320VSD	Cooling Capacity	174.7RT	614.4kW	195.5RT	687.7kW	614.1RT	2160.1kW	494.8RT	1740.5kW	207.3RT	729.1kW	750.0RT	2638.1kW	498.1RT	1752.0kW
	Absorbed Power	530.9HP	395.9kW	205.7HP	153.4kW	732.3HP	546.1kW	673.5HP	502.2kW	721.9HP	538.3kW	974.2HP	726.5kW	572.9HP	427.2kW
320VMD	Cooling Capacity	217.3RT	764.3kW	243.9RT	857.9kW	766.2RT	2695.0kW	617.4RT	2171.5kW	255.4RT	898.4kW	935.7RT	3291.3kW	622.2RT	2188.6kW
	Absorbed Power	655.2HP	488.6kW	254.1HP	189.5kW	904.8HP	674.7kW	832.1HP	620.5kW	887.6HP	661.9kW	1203.5HP	897.5kW	707.6HP	527.7kW
320VLD	Cooling Capacity	254.9RT	896.5kW	286.6RT	1008.1kW	900.2RT	3166.5kW	725.4RT	2551.4kW	298.5RT	1050.0kW	1099.4RT	3867.2kW	739.1RT	2599.6kW
	Absorbed Power	769.2HP	573.6kW	298.5HP	222.6kW	1062.9HP	792.6kW	977.5HP	728.9kW	1040.3HP	775.8kW	1413.8HP	1054.3kW	831.3HP	619.9kW

* The machine cannot be used under certain conditions. Please consult us for further details.

Outer dimensions

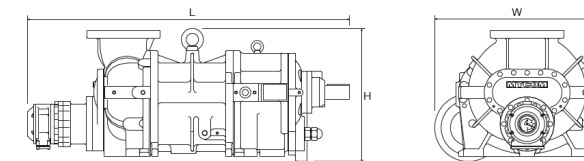

Model	Weight	W	L	H	
160V	SD	816lb/370kg	19"/470mm	41"/1029mm	17"/431mm
	MD	838lb/380kg	19"/470mm	42"/1074mm	17"/431mm
	LD	860lb/390kg	19"/470mm	44"/1119mm	17"/431mm
200V	SD	1389lb/630kg	26"/657mm	47"/1201mm	21"/540mm
	MD	1477lb/670kg	26"/657mm	50"/1258mm	21"/540mm
	LD	1543lb/700kg	26"/657mm	52"/1313mm	21"/540mm
250V	SD	2601lb/1180kg	31"/789mm	55"/1397mm	26"/655mm
	MD	2690lb/1220kg	31"/789mm	58"/1469mm	26"/655mm
	LD	2866lb/1300kg	31"/789mm	61"/1537mm	26"/655mm
	LLD	3064lb/1390kg	31"/789mm	64"/1615mm	26"/655mm
320V	SD	4938lb/2240kg	39"/996mm	71"/1798mm	34"/861mm
	MD	5467lb/2480kg	39"/996mm	74"/1886mm	34"/861mm
	LD	5820lb/2640kg	39"/996mm	78"/1973mm	34"/861mm

* The outer dimension drawings illustrate the model 200VLD. * Please contact us separately for models with a designation ending with G (downward discharge).

* Please consult us for further details.

C-SERIES

Screw Compressor [Two Stage] Open Type

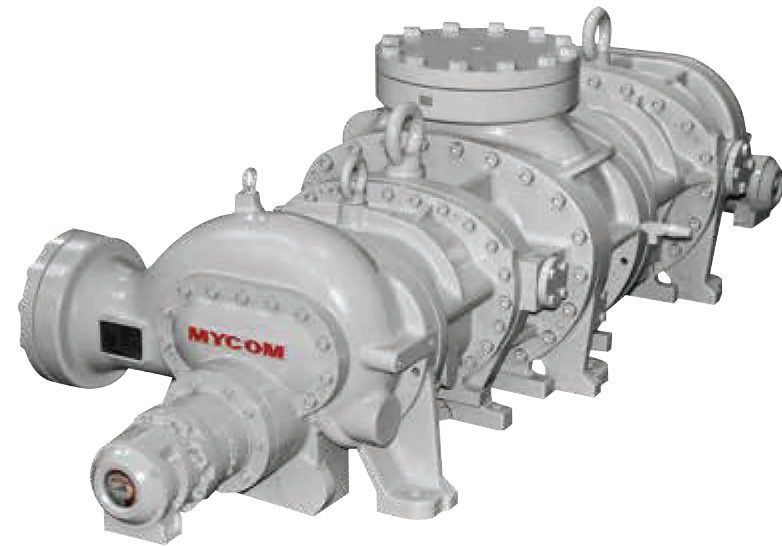

Single Machine / Two-stage Compression to Efficiently Cover Low Temperature Ranges

Wide-ranging Lineup

Available in 6 models with different rotor diameter configurations to cover a wide displacement* range from 216 CFM to 1866CFM (367 m³/h to 9,700 m³/h).

* This catalog lists representative models combined with standard rotor length. Please contact us separately for available variants.

MYCOM's Unique Industrial Compound Compressor

Needs only one motor and oil separator and thus contributes to space saving.

Longtime Seller

A lineup of medium - to large - sized two-stage compressors with a proven 4:6 rotor configuration.

Performance charts

Refrigerant	Temperature condition	Ammonia		R404A	
		-40/+35°C • -40/+95°F		-40/+35°C • -40/+95°F	
Model		Liquid Subcooling: 5°C/ 9°F Suction Superheat: 0°C/0°F Rotation speed: 2950rpm		Liquid Subcooling: 5°C/ 9°F Suction Superheat: 20°C/36°F Rotation speed: 2950rpm	
1610SLC-52 ^{*1}	Cooling Capacity	18.5RT	65.2kW	22.3RT	78.5kW
	Absorbed Power	57.4HP	42.8kW	78.9HP	58.8kW
1612LSC	Cooling Capacity	32.4RT	114.1kW	38.6RT	135.7kW
	Absorbed Power	90.5HP	67.5kW	127.3HP	94.9kW
2016LSC	Cooling Capacity	66.6RT	234.4kW	80.0RT	281.4kW
	Absorbed Power	181.0HP	135.0kW	253.2HP	188.8kW
2520LSC	Cooling Capacity	131.6RT	462.8kW	157.8RT	555.2kW
	Absorbed Power	351.2HP	261.9kW	490.9HP	366.1kW
3225LSC	Cooling Capacity	258.7RT	909.8kW	311.2RT	1094.7kW
	Absorbed Power	678.7HP	506.1kW	949.7HP	708.2kW
4032LSC	Cooling Capacity	529.2RT	1861.4kW	632.5RT	2224.9kW
	Absorbed Power	1415.8HP	1055.8kW	2003.9HP	1494.3kW

*1. Values at 1450 rpm are listed for the 1610SLC-52.

* The machine cannot be used under certain conditions. Please consult us for further details.

Specifications

Item	Model (N/F) ^{*1}		1610SLC-52 ^{*2}		1612LSC		2016LSC		2520LSC		3225LSC		4032LSC	
	Low Stage	High Stage	Low Stage	High Stage	Low Stage	High Stage	Low Stage	High Stage	Low Stage	High Stage	Low Stage	High Stage	Low Stage	High Stage
Refrigerant	Ammonia / HFC													
Theoretical displacement	2950rpm	CFM	216	79	366	116	712	305	1389	477	2790	930	5709	1866
	3550rpm	CFM	216	79	441	139	859	294	1672	574	3355	1118	6886	2248
Theoretical displacement	2950rpm	m ³ /h	367 ^{*3}	135 ^{*3}	622	197	1210	519	2360	810	4740	1580	9700	3170
	3550rpm	m ³ /h	367 ^{*4}	135 ^{*4}	749	237	1460	499	2840	975	5700	1900	11700	3820
Minimum rotation speed	rpm	1450												
Maximum rotation speed	rpm	1450		4500				3600						
Rotation direction		CW as viewed from motor			CCW as viewed from motor									
Capacity control	%	30 - 100												
Gas inlet port		MYCOM 125A ^{*5}	MYCOM 125A ^{*5}	JIS20K 150A	JIS20K 250A	JIS20K 350A	ANSI#300 16"							
Gas outlet port		JIS20K 50A	MYCOM 65A ^{*5}	JIS20K 80A	JIS20K 100A	JIS20K 150A	ANSI#300 8"							

*1. Specify the refrigerant by adding a prefix to the model code (N = ammonia / F = fluorocarbons). *2. The model 1610SLC-52 includes an internal step-up gear.

*3. Value at 1450 rpm. *4. Value at 1750 rpm of the model 1610SLC-62. *5. Flanges with a designation starting with MYCOM are in-house products of MYCOM.

* The range of rotation speed varies by operating conditions. Please refer to the ranges of use stated in the operating instructions.

Outer dimensions

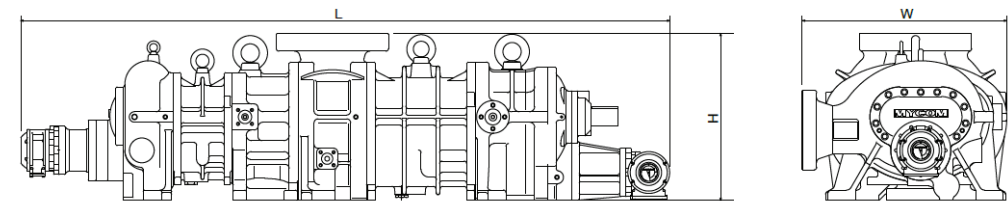

Model	Weight	W	L	H
1610SLC-52 ^{*1}	1345lb/610kg	25"/629mm	55"/1400mm	20"/511mm
1612LSC	1102lb/500kg	20"/511mm	52"/1321mm	19"/493mm
2016LSC	2425lb/1100kg	26"/657mm	67"/1691mm	20"/513mm
2520LSC	4519lb/2050kg	31"/785mm	98"/2487mm	25"/640mm
3225LSC	7297lb/3310kg	37"/945mm	107"/2715mm	33"/832mm
4032LSC	20613lb/9350kg	46"/1181mm	107"/2730mm	51"/1305mm

*1. Dimensions of the model 1610SLC-52 include an internal step-up gear.

* The outer dimension drawings illustrate the model 2520LSC. * Please consult us for further details.

i-SERIES

Screw Compressor [Single Stage] Open Type



Facilitates Design of Packaged Systems

Featuring a built-in suction strainer and check valve, the i-series screw compressor supports flange motors and facilitates the design of packaged systems.

New Design Eliminates the Need for an Oil Pump

The newly adopted ball bearings enable the i-series screw compressor to deliver high performance without a need of an oil pump.

Space Saving Design

Using a flange motor, the small-footprint compressor can be installed in a confined space.

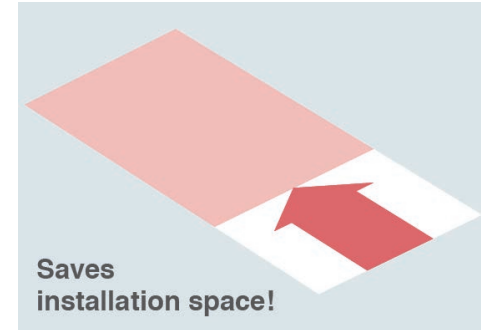

Easily Maintainable

Designed to facilitate the replacement of consumables.

Specifications

Item	Model	i125		i160			
		S	L	S	M	L	
Refrigerant		Ammonia / HFC					
Theoretical displacement	2950rpm	CFM	116	174	244	305	366
	3550rpm	CFM	139	210	294	367	441
Theoretical displacement	2950rpm	m ³ /h	197	296	415	519	622
	3550rpm	m ³ /h	237	356	499	624	749
Minimum rotation speed	rpm	1450 ^{*1}					
Maximum rotation speed	rpm	4500	3550	4500	3550	3550	
Rotation direction		CW as viewed from motor					
Capacity control	%	50/75/ 100					
Gas inlet port		MYCOM 100A ^{*2}		ANSI#300 5"			
Gas outlet port		MYCOM 65CD ^{*2}		ANSI#300 3"			
Flange motor connection	NEMA	3**C/40*C		3**D/4**D			
	IEC	FF400	FF500	FF500/FF600			

* 1. The range of rotation speed varies by operating conditions. Please refer to the ranges of use stated in the operating instructions.
* 2. Flanges with a designation starting with MYCOM are in-house products of MYCOM.

Performance charts

Refrigerant	Temperature condition	Ammonia				R404A				R134a	
		-40/+35°C • -40/+95°F		-10/+35°C • +14/+95°F		-40/+35°C • -40/+95°F		0/+40°C • +32/+104°F		+2/+42°C • +36/+108°F	
Model		Liquid Subcooling: 5°C/ 9°F Suction Superheat: 0°C/0°F Rotation speed: 2950rpm Economizer-type		Liquid Subcooling: 5°C/ 9°F Suction Superheat: 0°C/0°F Rotation speed: 2950rpm		Liquid Subcooling: 5°C/ 9°F Suction Superheat: 25°C/45°F Rotation speed: 2950rpm Economizer-type		Liquid Subcooling: 5°C/ 9°F Suction Superheat: 25°C/45°F Rotation speed: 2950rpm		Liquid Subcooling: 5°C/ 9°F Suction Superheat: 25°C/45°F Rotation speed: 2950rpm	
i125S	Cooling Capacity	9.6RT	33.9kW	35.8RT	125.9kW	11.5RT	40.6kW	43.9RT	154.5kW	28.7RT	100.9kW
	Absorbed Power	35.0HP	26.1kW	47.3HP	35.3kW	46.1HP	34.4kW	63.0HP	47.0kW	35.7HP	26.6kW
i125L	Cooling Capacity	14.5RT	51.0kW	53.5RT	188.1kW	17.0RT	59.9kW	65.5RT	230.4kW	43.6RT	153.3kW
	Absorbed Power	51.1HP	38.1kW	69.1HP	51.5kW	66.9HP	49.9kW	91.9HP	68.5kW	53.5HP	39.9kW
i160S	Cooling Capacity	21.4RT	75.2kW	77.6RT	272.9kW	25.3RT	89.0kW	94.9RT	333.9kW	62.1RT	218.6kW
	Absorbed Power	73.9HP	55.1kW	99.6HP	74.3kW	97.2HP	72.5kW	132.5HP	98.8kW	75.0HP	55.9kW
i160M	Cooling Capacity	26.7RT	94.0kW	97.1RT	341.6kW	31.5RT	110.9kW	119.0RT	418.5kW	78.4RT	275.6kW
	Absorbed Power	89.2HP	66.5kW	120.0HP	89.5kW	117.1HP	87.3kW	159.6HP	119.0kW	92.0HP	68.6kW
i160L	Cooling Capacity	32.0RT	112.6kW	116.4RT	409.4kW	37.9RT	133.5kW	142.8RT	502.4kW	94.6RT	332.8kW
	Absorbed Power	105.8HP	78.9kW	142.5HP	106.3kW	138.8HP	103.5kW	189.6HP	141.4kW	110.4HP	82.3kW

* Please consult us for further details.

Outer dimensions

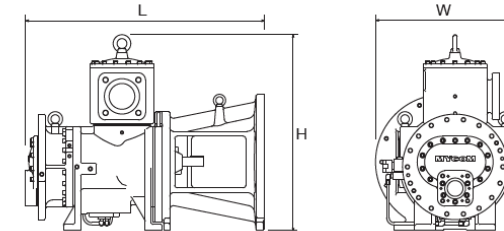

Model	Weight	W	L	H	
i125S	w/o motor spacer	728lb/330kg	22"/555mm	26"/656mm	31"/799mm
	NEMA	1080lb/490kg	22"/550mm	33"/831mm	31"/799mm
	IEC FF400	970lb/440kg	22"/555mm	36"/906mm	31"/799mm
i125L	w/o motor spacer	772lb/350kg	21"/535mm	29"/726mm	31"/799mm
	NEMA	1124lb/510kg	21"/530mm	35"/901mm	31"/799mm
	IEC FF500	1058lb/480kg	22"/560mm	38"/976mm	31"/799mm
i160S	w/o motor spacer	1146lb/520kg	24"/619mm	30"/773mm	29"/745mm
	NEMA	1477lb/670kg	27"/694mm	38"/974mm	29"/745mm
	IEC FF500	1389lb/630kg	25"/629mm	40"/1023mm	29"/745mm
	FF600	1455lb/660kg	27"/682mm	40"/1023mm	29"/745mm
i160M	w/o motor spacer	1235lb/560kg	24"/619mm	32"/818mm	29"/745mm
	NEMA	1565lb/710kg	27"/694mm	40"/1019mm	29"/745mm
	IEC FF500	1477lb/670kg	25"/629mm	42"/1068mm	29"/745mm
	FF600	1543lb/700kg	27"/682mm	42"/1068mm	29"/745mm
i160L	w/o motor spacer	1323lb/600kg	24"/619mm	34"/863mm	29"/745mm
	NEMA	1653lb/750kg	27"/694mm	42"/1064mm	29"/745mm
	IEC FF500	1565lb/710kg	25"/629mm	44"/1113mm	29"/745mm
	IEC FF600	1631lb/740kg	27"/682mm	44"/1113mm	29"/745mm

* The outer dimension drawings illustrate the model i125JL with an IEC FF500 motor spacer.

* Please consult us for further details.

UD-SERIES

Screw Compressor [Single Stage] Open Type



Supports Large-Capacity Range

A lineup of high-capacity compressors with a displacement of up to 9,182 CFM (15,600 m³/h), which is not available in the V-series.

Applications

Operates over a wide range of temperature and serves in industrial refrigerating and freezing applications. Also, workable as a booster compressor.

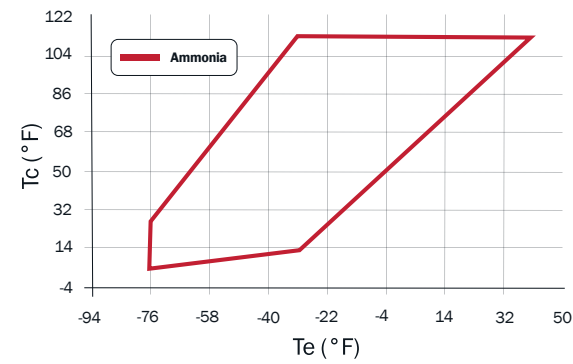

* The temperature range varies by model.

Longtime Seller

With a proven 4:6 rotor configuration, the UD-series offers optimal performance to customers.

Performance charts

Refrigerant	Temperature condition	Ammonia				Propane		R404A				R134a			
		-40/+35°C • -40/+95°F		-40/-10°C • -40/+14°F		-10/+35°C • +14/+95°F		-10/+35°C • +14/+95°F		-40/+35°C • -40/+95°F 400LL @ -40/+30°C 400LL @ -40/+86°F		0/+40°C • +32/+104°F 400LL @ 0/+30°C 400LL @ +32/+86°F		+2/+42°C • +36/+108°F	
Model		Liquid Subcooling: 5°C/9°F Suction Superheat: 0°C/0°F Rotation speed: 2950rpm Economizer-type		Liquid Subcooling: 5°C/9°F Suction Superheat: 0°C/0°F Rotation speed: 2950rpm		Liquid Subcooling: 5°C/9°F Suction Superheat: 0°C/0°F Rotation speed: 2950rpm		Liquid Subcooling: 5°C/9°F Suction Superheat: 10°C/0°F Rotation speed: 2950rpm		Liquid Subcooling: 5°C/9°F Suction Superheat: 25°C/0°F Rotation speed: 2950rpm Economizer-type		Liquid Subcooling: 5°C/9°F Suction Superheat: 25°C/0°F Rotation speed: 2950rpm		Liquid Subcooling: 5°C/9°F Suction Superheat: 25°C/0°F Rotation speed: 2950rpm	
125SUD/G	Cooling Capacity	9.6RT	33.9kW	—	—	35.8RT	125.9kW	28.9RT	101.7kW	11.5RT	40.6kW	43.9RT	154.5kW	28.7RT	100.9kW
	Absorbed Power	33.9HP	25.3kW	—	—	47.3HP	35.3kW	43.6HP	32.5kW	46.1HP	34.4kW	63.0HP	47.0kW	35.7HP	26.6kW
125LUD/G	Cooling Capacity	14.5RT	51.0kW	—	—	53.5RT	188.1kW	43.1RT	151.7kW	17.0RT	59.9kW	65.5RT	230.4kW	43.6RT	153.3kW
	Absorbed Power	49.5HP	36.9kW	—	—	69.1HP	51.5kW	63.4HP	47.3kW	66.9HP	49.9kW	91.9HP	68.5kW	53.5HP	39.9kW
400SUD	Cooling Capacity	345.2RT	1214.2kW	391.9RT	1378.3kW	1230.9RT	4329.6kW	991.8RT	3488.5kW	396.0RT	1392.9kW	1503.3RT	5287.6kW	1010.4RT	3553.9kW
	Absorbed Power	1104.7HP	823.8kW	432.9HP	322.8kW	1541.3HP	1149.4kW	1417.4HP	1057.0kW	1481.3HP	1104.6kW	2050.4HP	1529.0kW	1205.6HP	899.0kW
400MUD	Cooling Capacity	431.4RT	1517.3kW	492.3RT	1731.5kW	1546.3RT	5438.9kW	1245.9RT	4382.3kW	490.3RT	1724.7kW	1888.4RT	6642.4kW	1269.2RT	4464.3kW
	Absorbed Power	1383.9HP	1032.0kW	543.8HP	405.5kW	1936.3HP	1443.9kW	1780.6HP	1327.8kW	1850.7HP	1380.1kW	2575.7HP	1920.7kW	1514.4HP	1129.3kW
400LUD	Cooling Capacity	512.6RT	1803.0kW	586.6RT	2063.2kW	1842.5RT	6480.9kW	1484.6RT	5222.0kW	580.2RT	2040.7kW	2250.2RT	7915.0kW	1512.4RT	5319.9kW
	Absorbed Power	1646.6HP	1227.9kW	648.0HP	483.2kW	2307.2HP	1720.5kW	2121.7HP	1582.2kW	2199.6HP	1640.3kW	3069.1HP	2288.7kW	1804.6HP	1345.7kW
400LLUD	Cooling Capacity	601.1RT	2114.3kW	693.7RT	2439.9kW	2178.9RT	7664.2kW	1755.7RT	6175.4kW	716.3RT	2519.6kW	3088.6RT	10864.0kW	1793.1RT	6307.1kW
	Absorbed Power	1939.2HP	1446.1kW	766.2HP	571.4kW	2728.4HP	2034.6kW	2509.1HP	1871.1kW	2385.8HP	1779.1kW	2958.2HP	2206.0kW	2134.1HP	1591.4kW
400XLUD	Cooling Capacity	—	—	778.8RT	2739.5kW	—	—	—	—	—	—	—	—	—	—
	Absorbed Power	—	—	860.4HP	641.6kW	—	—	—	—	—	—	—	—	—	—

* The machine cannot be used under certain conditions. Please consult us for further details.

Specifications

Item	Model (N/P/F) ^{*1 *2}		125		400				
	SUD	LUD	SUD	MUD	LUD	LLUD	XLUD		
Refrigerant	Ammonia / Propane, propylene / HFCs								
Theoretical displacement	2950rpm	CFM	116	174	3814	4791	5709	6769	7593
	3550rpm	CFM	139	210	4591	5768	6886	8122	9182
Theoretical displacement	2950rpm	m ³ /h	197	295	6480	8140	9700	11500	12900
	3550rpm	m ³ /h	237	356	7800	9800	11700	13800	15600
Minimum rotation speed	rpm	1450 ^{*3}		1450 ^{*3}					
Maximum rotation speed	rpm	4500 ^{*3}		3600 ^{*3}					
Rotation direction	CCW as viewed from motor								
Capacity control	%	30-100							
Gas inlet port	MYCOM 100A ^{*4}			ANSI#300 16"					
Gas outlet port	MYCOM 65CD ^{*4}			ANSI#300 12"					

* 1. Specify the refrigerant by adding a prefix to the model code (N = ammonia / P = propane, propylene / F = fluorocarbons).
 * 2. Please contact us separately for models with a designation ending with G (downward discharge).
 * 3. The range of rotation speed varies by operating conditions. Please refer to the ranges of use stated in the operating instructions.
 * 4. Flanges with a designation starting with MYCOM are in-house products of MYCOM.

Outer dimensions

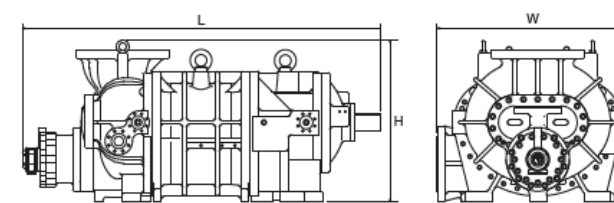

Model	Weight	W	L	H
125SUD	441lb/200kg	16"/404mm	33"/846mm	15"/386mm
125LUD	485lb/220kg	16"/404mm	36"/916mm	15"/386mm

Model	Weight	W	L	H
400SUD	11707lb/5310kg	51"/1290mm	83"/2109mm	44"/1120mm
400MUD	13580lb/6160kg	51"/1290mm	90"/2275mm	44"/1120mm
400LUD	15454lb/7010kg	51"/1290mm	98"/2491mm	44"/1120mm
400LLUD	17218lb/7810kg	51"/1290mm	103"/2613mm	44"/1120mm
400XLUD	19577lb/8880kg	51"/1290mm	107"/2716mm	44"/1120mm

* The outer dimension drawings illustrate the model 400LUD. * Please contact us separately for models with a designation ending with G (downward discharge).
 * Please consult us for further details.

MHS-SERIES

Screw Compressor [Two Stage] Open Type



High Efficiency

The water-cooled semi-hermetic motor, as well as Mayekawa's unique rotor design featuring different diameters, enables high efficiency.

Allows Compact Packaging

The semi-hermetic motor, as well as the integral oil separator, enables compact packaging of the MHS series.

Reduced Noise and Vibration

New Design Eliminates the Need for an Oil Pump

The newly adopted ball bearings eliminate the need for an oil pump and enable the delivery of high performance.

Performance charts

Refrigerant		R404A	
Temperature condition		-40/+35°C • -40/+95°F	
Model		Liquid Subcooling: 5°C/ 9°F Suction Superheat: 20°C/36°F Rotation speed: 2950rpm	
22H1290SSC	Cooling Capacity	9.3RT	32.6kW
	Absorbed Power	30.8HP	23.0kW
37H1410SSC	Cooling Capacity	15.2RT	53.5kW
	Absorbed Power	47.5HP	35.4kW

* The machine cannot be used under certain conditions. Please consult us for further details.

Specifications

Item		Model		22H1290SSC		27H1290SSC		37H140SSC	
		Low Stage	High Stage	Low Stage	High Stage	Low Stage	High Stage		
Refrigerant		R404A/R507A							
Theoretical displacement	2950rpm	CFM	85	32	85	32	131	49	
	3550rpm	CFM	103	39	103	39	158	59	
Theoretical displacement	2950rpm	m ³ /h	145	54.4	145	54.4	222	83.9	
	3550rpm	m ³ /h	175	65.6	175	65.6	268	101	
Minimum rotation speed	rpm	1500							
Maximum rotation speed	rpm	4200							
Capacity control	%	50/100							
Gas inlet port			50A ^{*1}				65A ^{*1}		
Gas outlet port			25A ^{*1}				32A ^{*1}		
Semi-hermetic moto	kW	22		27		37			

* 1. Mayekawa's uniquely designed flange is used.

* 2. The range of rotation speed varies by operating conditions. Please refer to the ranges of use stated in the operating instructions.

Outer dimensions

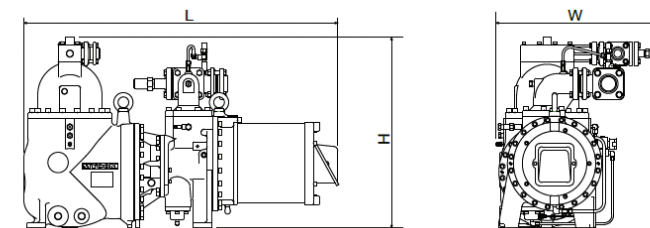

Model	Weight	W	L	H
22H1290SSC	1146lb/520kg	27"/693mm	52"/1312mm	31"/797mm
27H1290SSC	1235lb/560kg	27"/693mm	53"/1352mm	31"/797mm
37H1410SSC	1786lb/810kg	30"/765mm	58"/1472mm	35"/887mm

* The outer dimension drawings illustrate the model 37H1410SSC. * Please consult us for further details.

MYPRO TOUCH+ CONTROL PANEL



MYPRO TOUCH+

Control panel for MYCOM Screw Compressor Packages

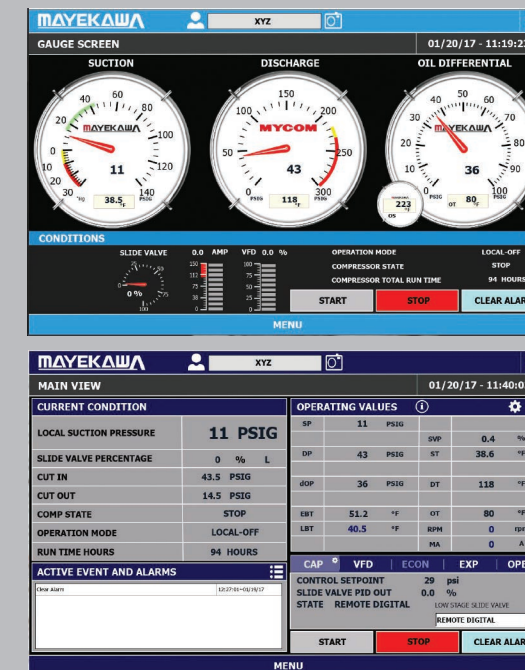

Screw Package Panel

The MYPRO TOUCH+ has control capabilities for screw compressor packages, chillers and basic system equipment such as compressor vibration sensors, motor temperatures and vessel levels.

Standard Features

- » 13.3" widescreen touch
- » APP style menu interface
- » Ethernet connectivity
- » SD card storage
- » Onboard
 - Operating instruction manual
 - Data sheets
 - Drawings
 - Instructional videos
- » Communications
 - Legacy Modbus RTU
 - Modbus TCP/IP
 - Allen Bradley Logix drivers
 - VNC technology for remote desktop
- » Password protection
- » Real time and historical trending
- » Email alarm notification

Specifications

Screen Size	13.3" Diagonal	Display Resolution	1280 x 800
Communication	RS-485 Ethernet (2) USB (2)	Control Voltage	100V~120V / 220V~240V
		Electrical Frequency	50 / 60Hz
		Ambient Temperature	32°F~122°F (0°C~50°C) 85% R.H.
Memory Storage	SD Card (32GB max.)	Dimensions	H30" x W24" x D10" H762mm x W610mm x D254mm
Analog Input		Digital I/O	
Current	4-20 mA DC	Digital Input	Do NOT apply voltage to connection. Board supplies internal 12 VDC Max. 25 mA
Voltage	1-5 VDC		
Potentiometer	1-1000 ohm; Qty. 2		
Analog Output		Digital Output- Solid State Relay Ratings	100-240 VAC, 2A Leakage Current <1.5 mA
QTY	4		
Current Signal	4-20 mA DC Load resistance <500 ohm		

RECIPROCATING COMPRESSORS



- M-series
- K-series
- HS-series
- HK-series
- WBHE-series
- WA-series
- L-series

For 95 years since Mayekawa started manufacturing piston compressors, Mayekawa has listened to the customers' demand to advance its technology to develop MYCOM Reciprocating Compressors. Mayekawa has a full-lineup of compressors that cover a wide range of applications with various pressures and volumes.

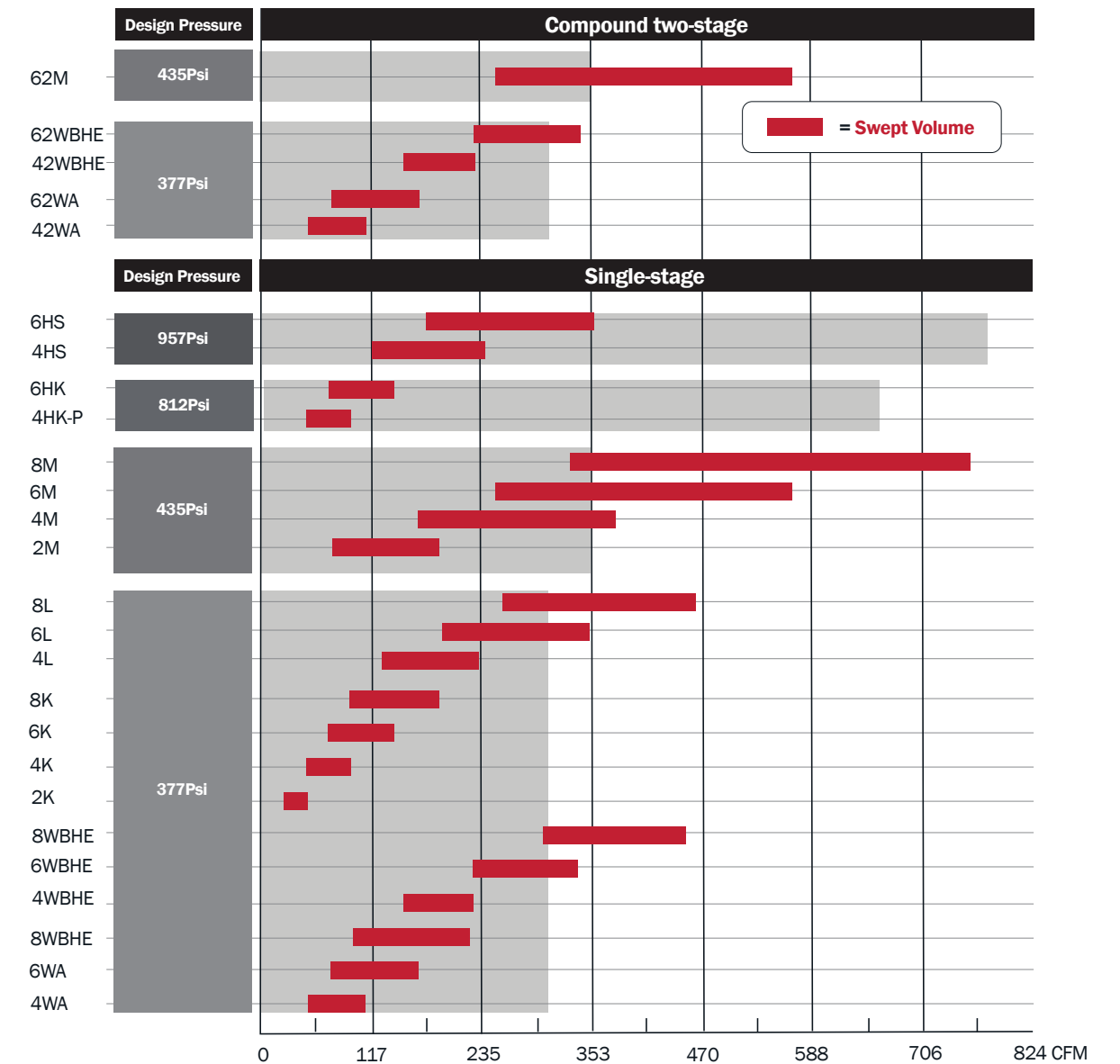

Compound two-stage
 62M-series: 660-1500rpm / 42/62WBHE-series: 800-1200rpm / 42/62WA-series: 650-1450rpm

Single-stage
 4/6HS-series: 750-1500rpm / 4/6HK-series: 900-1800rpm / 2-8M-series: 660-1500rpm / 4-8L-series: 970-1750rpm / 2-8K-series: 900-1800rpm / 4-8WBHE-series: 800-1200rpm / 4-8WA-series: 650-1450rpm

M-SERIES

Reciprocating Compressor [Single Stage] Open Type & [Two Stage] Open Type



High Performance Derived from New Design

This newly designed compressor minimizes internal heating of the intake gas resulting in the highest level of performance in our product portfolio.

Much Improved Overhaul Intervals

The M-series incorporates a new valve structure with improved durability and dramatically extended overhaul intervals of 16,000 hours.

Supports a Wide Range of Pressure Conditions

The components are designed for high pressure applications and a wide range of operating conditions. The M-series can be used in demanding applications such as high pressure systems and heat pumps.

Easy Maintenance

Hydraulic lines for capacity control are incorporated into the casing design, allowing simplified package designs as well as easy replacement of consumable components.

Multiple Applications

Multiple configurations are available in drive type (direct drive/belt drive) and refrigerant compatibility (Ammonia, Propane and Fluorocarbon refrigerants).

Performance charts

Ammonia

Condensing temp: 104°F Rotation speed: 970rpm
Suction superheat: 0°F Liquid Subcooling: 9°F

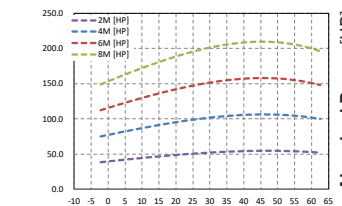
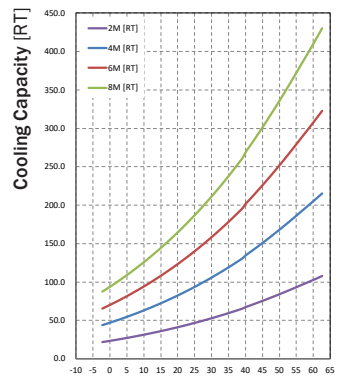

Propane

Condensing temp: 104°F Rotation speed: 970rpm
Suction superheat: 18°F Liquid Subcooling: 9°F

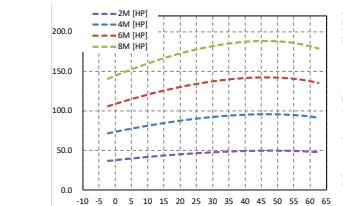
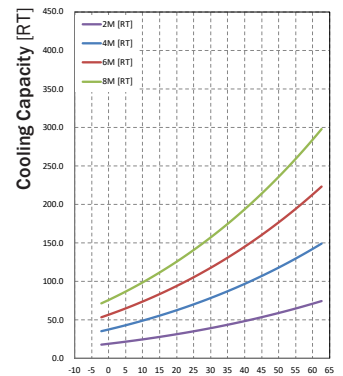

R404A

Condensing temp: 104°F Rotation speed: 970rpm
Suction superheat: 36°F Liquid Subcooling: 9°F

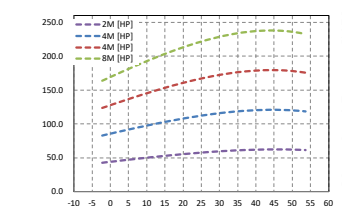
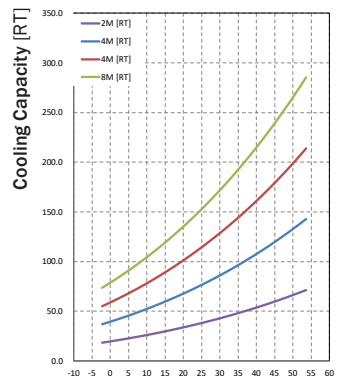

R134a

Condensing temp: 104°F Rotation speed: 970rpm
Suction superheat: 36°F Liquid Subcooling: 9°F

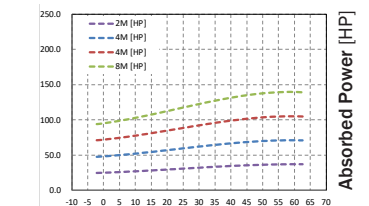
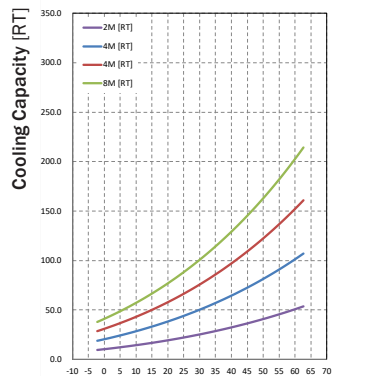

Specifications

*Some optional items are included in this photo.

Item	Model* ¹ (N/P/F)	2M	4M	6M	8M	62M
Refrigerant		Ammonia / Propane, Propylene / HFCs (R134a, R404A, R507A)				Ammonia / HFCs (R404A, R507A)
Compressor Type		Reciprocating, Open Type				
Number of Cylinders		2	4	6	8	Low Stage: 6 High Stage: 2
Bore		5.8" / 146mm				
Stroke		4.2" / 106mm				
Displacement* ²	CFM	122	243	365	486	Low Stage: 365 High Stage: 122
Displacement* ²	m ³ /h	207	413	620	826	Low Stage: 620 High Stage: 207
Rotation Speed	rpm	600-1500* ³				
Drive Method		Direct Drive / V-belt				Direct Drive / Overhang moto / V-belt
Capacity Control	%	100/50	100/50	100/66/33	100/75/50/25	100/66/33

*1. Specify the refrigerant by adding a prefix to the type code (N = Ammonia / P = Propane / F = Fluorocarbons).

*2. Displacement at 970 rpm

*3. The range of rotation speed varies by operating conditions. Please refer to the ranges of use stated in the operating instructions.

Outer dimensions

*Please consult us for compound performance charts or further details.

[Air cooled type (Propane, HFCs)]

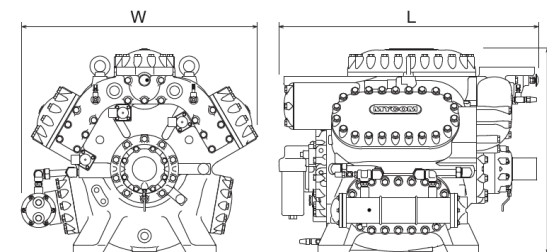

Model (P/F)	Weight	W	L	H
2M	1489lb/675kg	28"/715mm	42"/1070mm	35"/890mm
4M	2381lb/1080kg	39"/995mm	45"/1150mm	35"/890mm
6M	2888lb/1310kg	42"/1065mm	46"/1165mm	36"/920mm
8M	3384lb/1535kg	43"/1085mm	47"/1205mm	36"/910mm
62M	3726lb/1690kg	43"/1085mm	47"/1205mm	37"/930mm

* The outer dimension drawings illustrate the 6-cylinder model.

* The stop valve, companion flange, flywheel, V-pulley, and safety valve are not included. * The oil cooler is included.

[Water cooled type (Ammonia)]

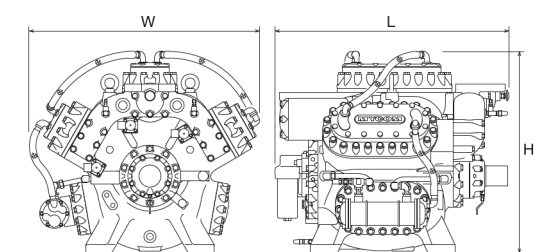

Model (N)	Weight	W	L	H
2M	1510lb/685kg	28"/715mm	42"/1070mm	38"/960mm
4M	2425lb/1100kg	40"/1020mm	45"/1150mm	40"/1025mm
6M	2954lb/1340kg	45"/1150mm	46"/1165mm	39"/1000mm
8M	3472lb/1575kg	45"/1150mm	47"/1205mm	40"/1020mm
62M	3814lb/1730kg	47"/1195mm	47"/1205mm	40"/1020mm

K-SERIES

Reciprocating Compressor [Single Stage] Open Type



Multiple Applications

Multiple configurations are available in drive type (direct/belt) and refrigerant compatibility (Ammonia, propane and fluorocarbon refrigerants). A compressor suited for many different refrigeration applications:

[Usable Refrigerants]

Natural Refrigerants

Ammonia
Propane
Propylene

Fluorocarbon Refrigerants

R134a
R407C
R407F
R404A
R507A

Supports a Wide Range of Pressure Conditions

The components are designed for high pressure applications and a wide range of operating conditions. The K-series can be used in demanding applications such as high pressure systems and heat pumps.

Variable Load Capability

A wide rotational speed range from 800 to 1800rpm provides a powerful output capacity.

Simplified Package Design

Hydraulic lines for capacity control are incorporated into the casing design, allowing for simplified package designs and easy maintenance.

Performance charts

Ammonia

Condensing temp: 104°F Rotation speed: 970rpm
Suction superheat: 0°F Liquid Subcooling: 9°F

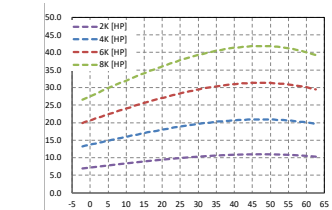
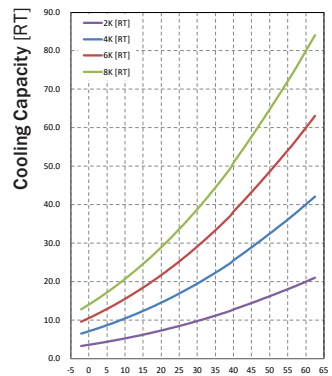

Propane

Condensing temp: 104°F Rotation speed: 970rpm
Suction superheat: 18°F Liquid Subcooling: 9°F

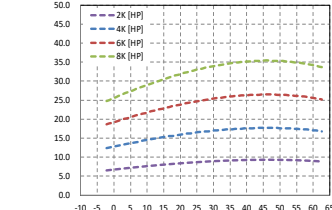
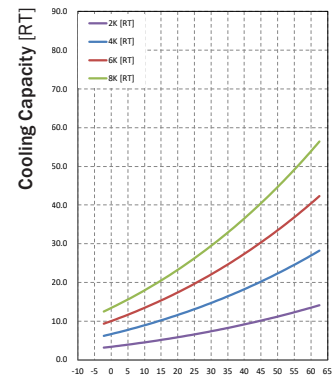

R404A

Condensing temp: 104°F Rotation speed: 970rpm
Suction superheat: 36°F Liquid Subcooling: 9°F

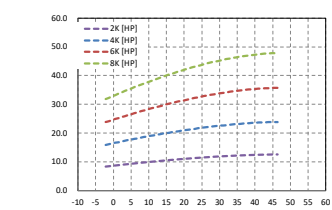
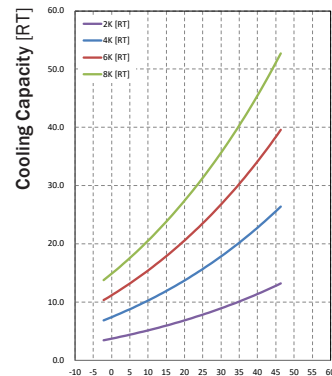

R134a

Condensing temp: 104°F Rotation speed: 970rpm
Suction superheat: 36°F Liquid Subcooling: 9°F

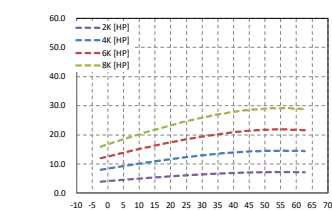
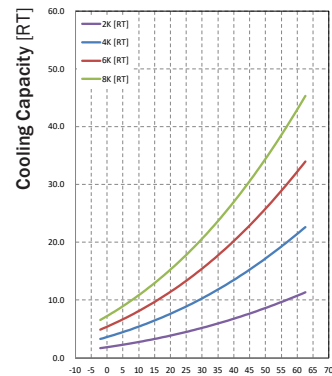

Specifications

*Some optional items are included in this photo.

Model*1 (N/P/F)		2K	4K	6K	8K	
Refrigerant		Ammonia / Propane, Propylene / HFCs (R134a, R407C, R407F, R404A, R507A)				
Compressor Type		Reciprocating, Open Type				
Number of Cylinders		2	4	6	8	
Bore		3.4" / 85mm				
Stroke		2.56" / 65mm				
Displacement*2	CFM	25.2	50.6	75.9	101.2	
Displacement*2	m ³ /h	42.9	85.9	129	172	
Rotation Speed	rpm	800-1800*3				
Drive Method		Direct Drive / V-belt				
Capacity Control	Ammonia	%	100/50	100/50	100/66/33	100/75/50/25
	Propane, Propylene / HFCs		100/50	100/75/50/25	100/83/66/50/33	100/75/50/25

*1. Specify the refrigerant by adding a prefix to the type code (N = Ammonia / P = Propane / F = Fluorocarbons).

*2. Displacement at 970 rpm

*3. The range of rotation speed varies by operating conditions. Please refer to the ranges of use stated in the operating instructions.

Outer dimensions

*Please consult us for compound performance charts or further details.

[Air cooled type (Propane, HFCs)]

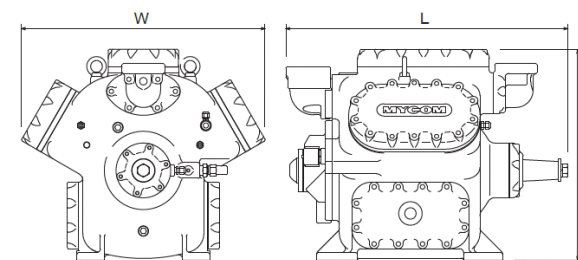

Model (P/F)	Weight	W	L	H
2K	397lb/180kg	18"/445mm	26"/665mm	21"/540mm
4K	606lb/275kg	22"/565mm	28"/715mm	21"/530mm
6K	705lb/320kg	25"/640mm	29"/725mm	22"/560mm
8K	838lb/380kg	25"/640mm	29"/740mm	22"/570mm

[Water cooled type (Ammonia)]

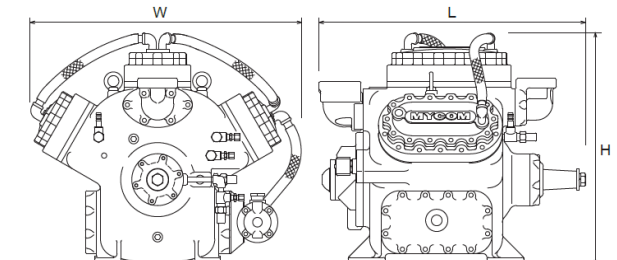

Model (N)	Weight	W	L	H
2K	408lb/185kg	20"/510mm	26"/665mm	25"/625mm
4K	628lb/285kg	25"/645mm	28"/715mm	22"/570mm
6K	750lb/340kg	29"/740mm	29"/725mm	25"/625mm
8K	893lb/405kg	30"/765mm	29"/740mm	26"/660mm

* The outer dimension drawings illustrate the 6-cylinder model.

* The stop valve, companion flange, flywheel, V-pulley, and safety valve are not included. * The oil cooler is included only for the water cooled type.

HK-SERIES

Reciprocating Compressor [Single Stage] Open Type



A Compressor Compatible with Ammonia Heat Pump Systems

Achieved condensing temperature at 85°C to operate with ammonia heat pump systems. This series can also be used for systems utilizing exhaust and waste heat.

50bar High Pressure Design

From CO₂ cascades to ammonia heat pumps, these compressors are designed for a wide temperature range. This series can also be used for CO₂ hot gas defrost systems.

High Reliability

Since its production launch in 2004, the HK series has become the trusted model for many applications.

Performance charts

Ammonia

Condensing temp: 185°F Rotation speed: 970rpm
Suction superheat: 0°F Liquid subcooling: 7°F

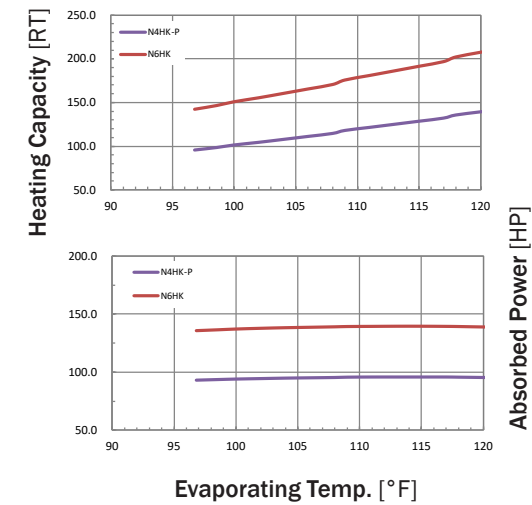

CO₂

Condensing temp: 14°F Rotation speed: 970rpm
Suction superheat: 0°F Liquid subcooling: 0°F

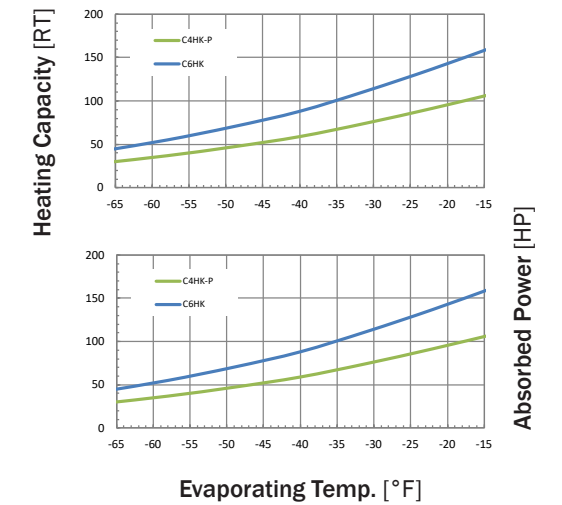

Specifications

*Some optional items are included in this photo.

Model* ¹ (N/C)		4HK-P	6HK
Item			
Refrigerant		Ammonia / CO ₂	
Compressor Type		Reciprocating, Open Type	
Number of Cylinders		4	6
Bore		3.4" / 85mm	
Stroke		2.6" / 65mm	
Displacement* ²	CFM	75.3	113.6
Displacement* ²	m ³ /h	128	193
Rotation Speed	rpm	900-1800* ³	
Drive Method		Direct Drive	
Capacity Control	%	100/50	100/66/33

*1. Specify the refrigerant by adding a prefix to the type code (N = Ammonia / C = CO₂).

*2. Displacement at 1450 rpm

*3. The range of rotation speed varies by operating conditions. Please refer to the ranges of use stated in the operating instructions.

Outer dimensions

*Please consult us for further details.

[Air cooled type (CO₂)]

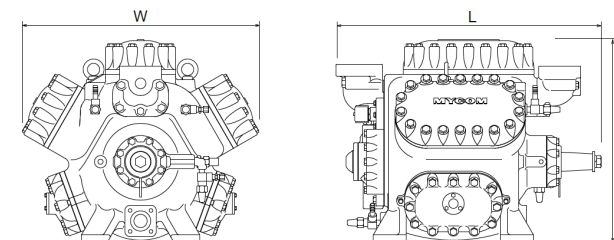

Model (C)	Weight	W	L	H
4HK-P	772lb/350kg	27"/680mm	31"/785mm	23"/585mm
6HK	772lb/350kg	27"/680mm	31"/785mm	23"/585mm

* The outer dimension drawings illustrate the 6-cylinder model.

* The stop valve, companion flange, flywheel, safety valve, and oil cooler are not included.

[Water cooled type (Ammonia)]

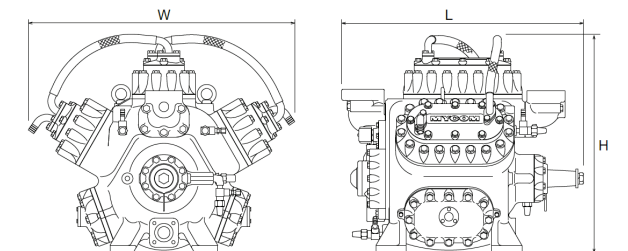

Model (N)	Weight	W	L	H
4HK-P	794lb/360kg	33"/840mm	31"/785mm	27"/685mm
6HK	794lb/360kg	33"/840mm	31"/785mm	27"/685mm

HS-SERIES

Reciprocating Compressor [Single Stage] Open Type



A Newly Designed Compressor Series Which Can Generate up to 194°F (90°C) Hot Water with Ammonia Heat Pump Systems

Oil consumption has been reduced through design review and achieved stable operation of ammonia heat pump systems. This series can also be used for systems utilizing exhaust and waste heat.

60bar High Pressure Design

Achieved higher pressure design compared with conventional high pressure compressors. From CO₂ cascades to ammonia heat pumps, these compressors can be utilized for a wide temperature range. This series can also be used for CO₂ hot gas defrost systems.

Achieved High Capacity

The HS series has a capacity at about 3 times as high compared with conventional high pressure compressors. This flexibly contributes to the application with large scale systems.

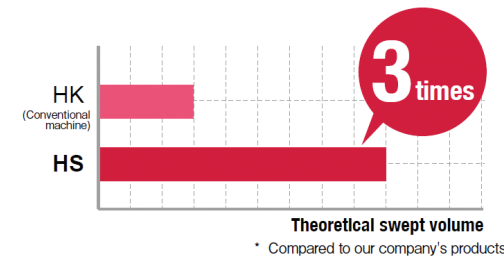

Performance charts

Ammonia

Condensing temp: 185°F Rotation speed: 970rpm
Suction superheat: 0°F Liquid subcooling: 7°F

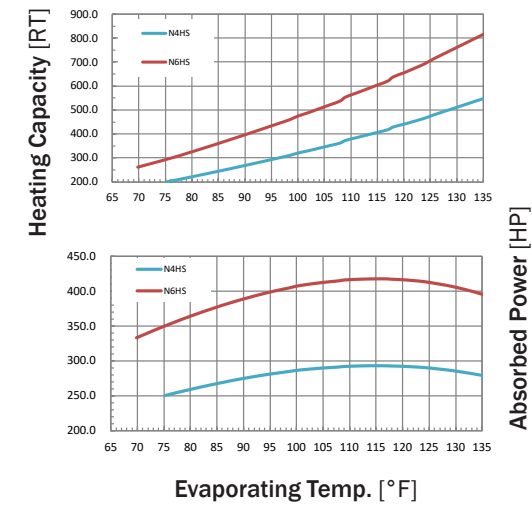

CO₂

Condensing temp: 14°F Rotation speed: 970rpm
Suction superheat: 0°F Liquid subcooling: 0°F

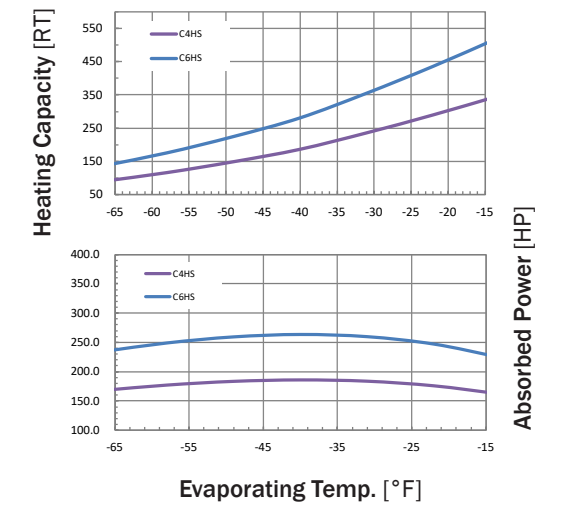

Specifications

*Some optional items are included in this photo.

Model* ¹ (N/C)		4HS	6HS
Item			
Refrigerant		Ammonia / CO ₂	
Compressor Type		Reciprocating, Open Type	
Number of Cylinders		4	6
Bore		5.1"/130mm	
Stroke		3.3"/84mm	
Displacement* ²	CFM	228.4	342.6
Displacement* ²	m ³ /h	388	582
Rotation Speed	rpm	750-1500* ³	
Drive Method		Direct Drive	
Capacity Control	%	100/75/50/25	100/83/66/50/33

*1. Specify the refrigerant by adding a prefix to the type code (N = Ammonia / C = CO₂).

*2. Displacement at 1450 rpm

*3. The range of rotation speed varies by operating conditions. Please refer to the ranges of use stated in the operating instructions.

Outer dimensions

*Please consult us for further details.

[Air cooled type (CO₂)]

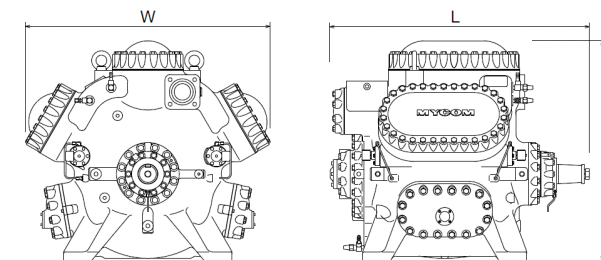

Model (C)	Weight	W	L	H
4HS	3527lb/1600kg	40"/1020mm	44"/1115mm	39"/1000mm
6HS	3968lb/1800kg	45"/1135mm	46"/1165mm	40"/1020mm

* The outer dimension drawings illustrate the 6-cylinder model.

* The stop valve, companion flange, flywheel, safety valve, and oil cooler are not included.

[Water cooled type (Ammonia)]

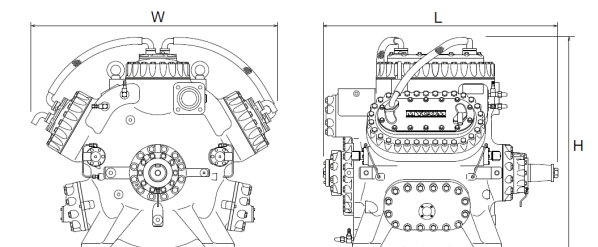

Model (N)	Weight	W	L	H
4HS	3638lb/1650kg	43"/1100mm	44"/1115mm	43"/1100mm
6HS	4079lb/1850kg	50"/1260mm	46"/1165mm	43"/1095mm

WBHE-SERIES

Reciprocating Compressor [Single Stage] Open Type & [Two Stage] Open Type



*Some optional items are included in this photo.

New Design with Enhanced Performance
Redesigned valve structure and reduced mechanical losses have achieved further improvements in performance compared to conventional models.

[COP improvement of WBHE series]

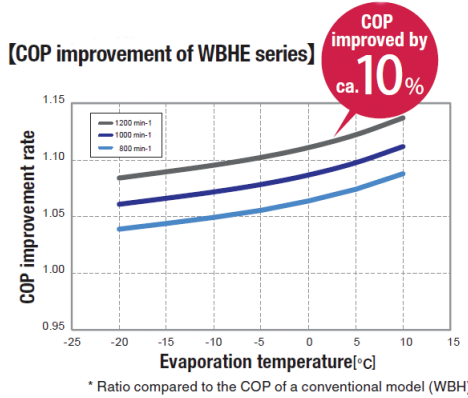

Applications

With a high-pressure design suitable for use in air-cooled condensing units for fluorocarbon refrigerants, the model operates over a wide range of temperature and serves in large-scale refrigerating and freezing applications.

[Usable Refrigerants]

Natural Refrigerants
Ammonia
Propane

Fluorocarbon Refrigerants
R134a
R404A
R507A
R23

Applications

A long-selling model with industry-leading reliability and track record, designed for tough applications subject to load fluctuation.

Specifications

Model ¹ (N/P/F)		4WBHE	6WBHE	8WBHE	42WBHE	62WBHE
Item						
Refrigerant		Ammonia / Propane / HFCs (R134a, R404A, R507A, R23 ²)			Ammonia / HFCs (R404A, R507A)	
Compressor Type		Reciprocating, Open Type				
Number of Cylinders		4	6	8	Low Stage: 4 High Stage: 2	Low Stage: 6 High Stage: 2
Bore		5.1"/130mm				
Stroke		3.9"/100mm				
Displacement ³	CFM	181.9	273.1	363.7	Low Stage: 181.9 High Stage: 91.2	Low Stage: 273.1 High Stage: 91.2
Displacement ³	m ³ /h	309	464	618	Low Stage: 309 High Stage: 155	Low Stage: 464 High Stage: 155
Rotation Speed	rpm	800-1200 ⁴				
Drive Method		Direct Drive / V-belt				
Capacity Control	%	100/50	100/66/33/0 ⁵	100/75/50/25/0 ⁵	100/50	100/66/33

*1. Specify the refrigerant by adding a prefix to the type code (N = Ammonia / P = Propane / F = Fluorocarbons).

*2. If R23 is to be used as the refrigerant, the machine will come with special specifications. Please contact us for detailed information.

*3. Displacement at 970 rpm

*4. The range of rotation speed varies by operating conditions. Please refer to the ranges of use stated in the operating instructions.

*5. The capacity control value of 0% can be realized by an optional feature. Please contact us for detailed information.

Performance charts

Ammonia

Condensing temp: 104°F Rotation speed: 970rpm
Suction superheat: 0°F Liquid Subcooling: 9°F

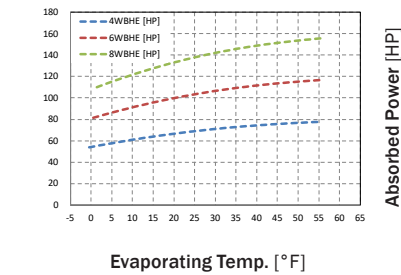
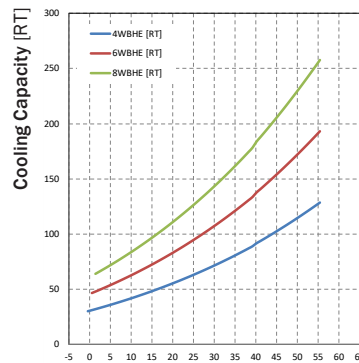

R404A

Condensing temp: 104°F Rotation speed: 970rpm
Suction superheat: 36°F Liquid Subcooling: 9°F

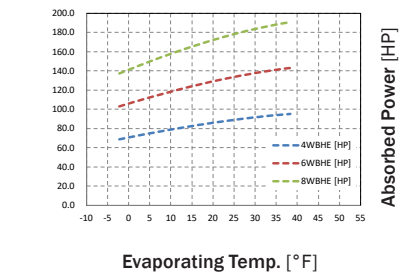
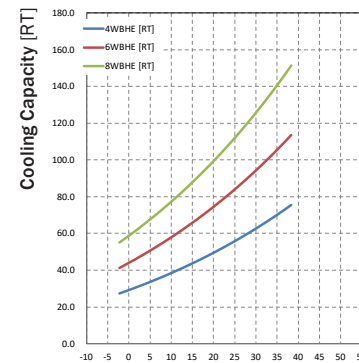

R134a

Condensing temp: 104°F Rotation speed: 970rpm
Suction superheat: 36°F Liquid Subcooling: 9°F

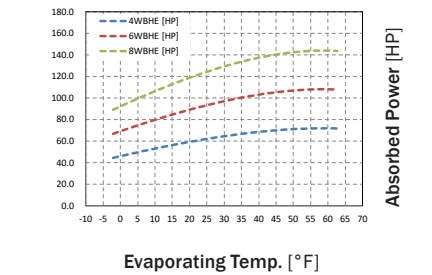
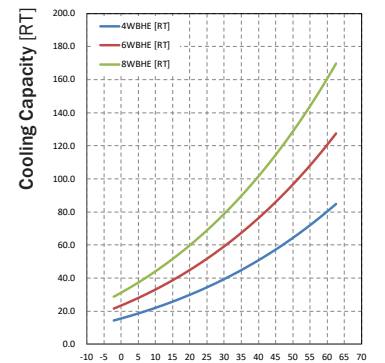

*Please consult us for compound performance charts or further details.

Outer dimensions

[Air cooled type (HFCs)]

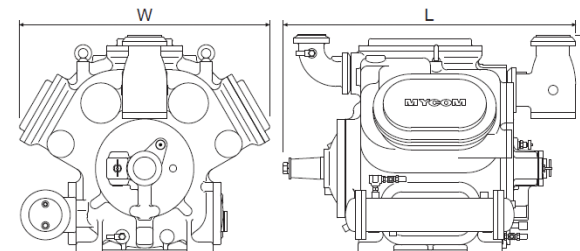

Model (P/F)	Weight	W	L	H
4WBHE	1929lb/875kg	39"/990mm	42"/1075mm	36"/920mm
6WBHE	2546lb/1155kg	42"/1060mm	49"/1240mm	36"/915mm
8WBHE	2745lb/1245kg	43"/1095mm	49"/1240mm	36"/905mm
42WBHE	2557lb/1160kg	42"/1065mm	48"/1225mm	35"/900mm
62WBHE	2844lb/1290kg	43"/1100mm	49"/1240mm	37"/950mm

* The outer dimension drawings illustrate the 6-cylinder model.

* The stop valve, companion flange, flywheel, V-pulley, and safety valve are not included. * The oil cooler is included.

[Water cooled type (Ammonia)]

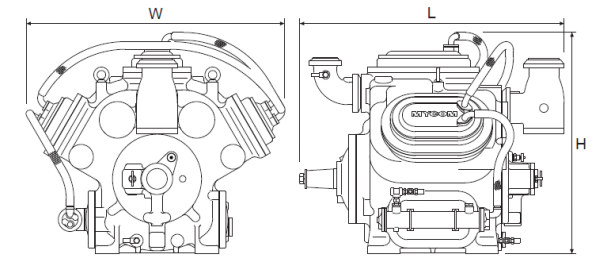

Model (N)	Weight	W	L	H
4WBHE	1962lb/890kg	41"/1050mm	42"/1075mm	36"/920mm
6WBHE	2601lb/1180kg	48"/1210mm	49"/1240mm	41"/1035mm
8WBHE	2822lb/1280kg	50"/1280mm	49"/1240mm	42"/1060mm
42WBHE	2624lb/1190kg	48"/1210mm	48"/1225mm	41"/1035mm
62WBHE	2932lb/1330kg	51"/1285mm	49"/1240mm	42"/1065mm

WA-SERIES

Reciprocating Compressor [Single Stage] Open Type & [Two Stage] Open Type



Applications

With a high-pressure design suitable for use in air-cooled condensing units for fluorocarbon refrigerants, the model operates over a wide range of temperature and serves in small to medium scale refrigerating and freezing applications.

[Usable Refrigerants]

Natural Refrigerants

Ammonia
Propane

Fluorocarbon Refrigerants

R134a
R404A
R507A
R23

High Reliability

A long-selling model with high reliability and track record, designed for tough applications subject to load fluctuation.

Performance charts

Ammonia

Condensing temp: 104°F Rotation speed: 970rpm
Suction superheat: 0°F Liquid Subcooling: 9°F

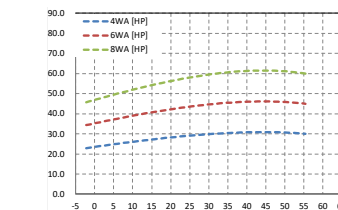
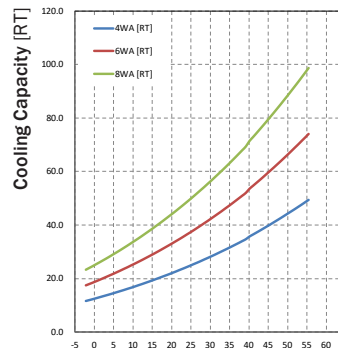

Propane

Condensing temp: 104°F Rotation speed: 970rpm
Suction superheat: 18°F Liquid Subcooling: 9°F

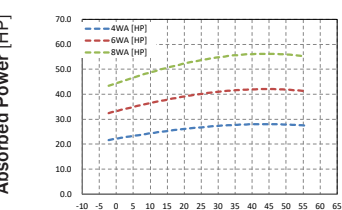
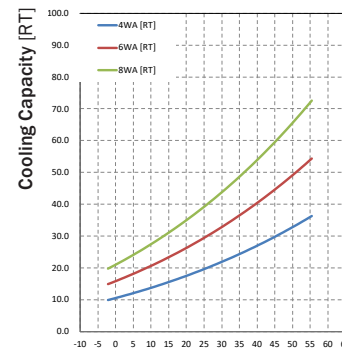

R404A

Condensing temp: 104°F Rotation speed: 970rpm
Suction superheat: 36°F Liquid Subcooling: 9°F

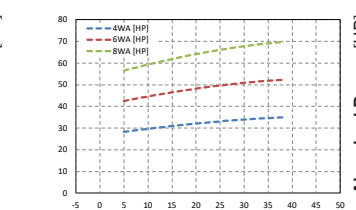
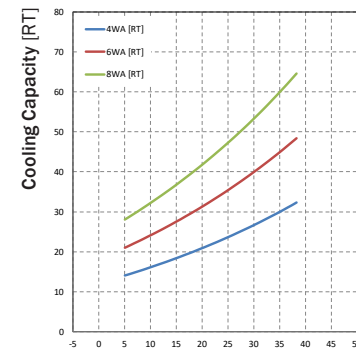

R134a

Condensing temp: 104°F Rotation speed: 970rpm
Suction superheat: 36°F Liquid Subcooling: 9°F

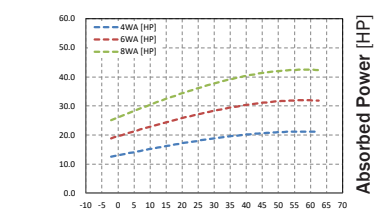
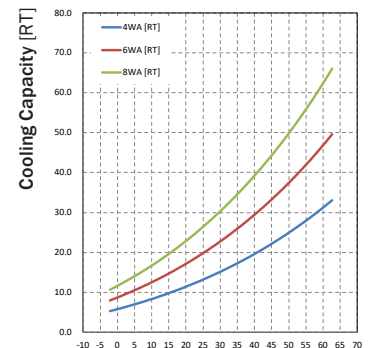

Specifications

*Some optional items are included in this photo.

Model*1 (N/P/F)		4WA	6WA	8WA	42WA	62WA
Refrigerant		Ammonia / Propane / HFCs (R134a, R404A, R507A, R23*2)			Ammonia / HFCs (R404A, R507A)	
Compressor Type		Reciprocating, Open Type				
Number of Cylinders		4	6	8	Low Stage: 4 High Stage: 2	Low Stage: 6 High Stage: 2
Bore		3.7"/95mm				
Stroke		2.9"/76mm				
Displacement*2	CFM	73.6	110.7	147.7	Low Stage: 73.6 High Stage: 36.9	Low Stage: 110.7 High Stage: 36.9
Displacement*2	m ³ /h	125	188	251	Low Stage: 125 High Stage: 67.2	Low Stage: 188 High Stage: 62.7
Rotation Speed	rpm	800-1500*4				
Drive Method		Direct Drive / V-belt				
Capacity Control	%	100/50	100/66/33	100/75/50/25	100/50	100/66/33

*1. Specify the refrigerant by adding a prefix to the type code (N = Ammonia / P = Propane / F = Fluorocarbons).

*2. If R23 is to be used as the refrigerant, the machine will come with special specifications. Please contact us for detailed information.

*3. Displacement at 970 rpm

*4. The range of rotation speed varies by operating conditions. Please refer to the ranges of use stated in the operating instructions.

Outer dimensions

*Please consult us for compound performance charts or further details.

[Air cooled type (Propane, HFCs)]

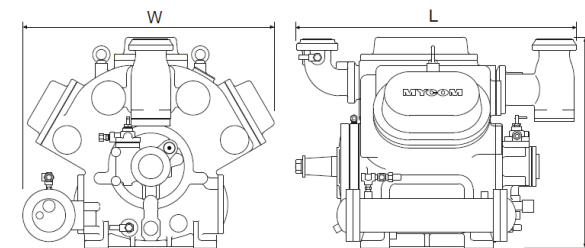

Model (P/F)	Weight	W	L	H
4WA	1014lb/460kg	30"/760mm	33"/835mm	28"/715mm
6WA	1224lb/555kg	34"/865mm	38"/960mm	26"/725mm
8WA	1422lb/645kg	36"/910mm	39"/980mm	30"/755mm
42WA	1279lb/580kg	33"/850mm	37"/935mm	29"/735mm
62WA	1477lb/670kg	35"/880mm	38"/970mm	30"/750mm

* The outer dimension drawings illustrate the 6-cylinder model.

* The stop valve, companion flange, flywheel, V-pulley, and safety valve are not included. * The oil cooler is included.

[Water cooled type (Ammonia)]

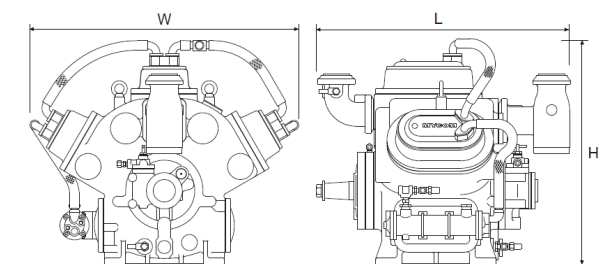

Model (N)	Weight	W	L	H
4WA	1047lb/475kg	34"/875mm	33"/835mm	29"/735mm
6WA	1257lb/570kg	41"/1050mm	38"/960mm	34"/855mm
8WA	1477lb/670kg	40"/1020mm	39"/980mm	34"/860mm
42WA	1323lb/600kg	39"/990mm	37"/935mm	33"/840mm
62WA	1543lb/700kg	41"/1045mm	38"/970mm	36"/910mm

L-SERIES

Reciprocating Compressor [Single Stage] Open Type

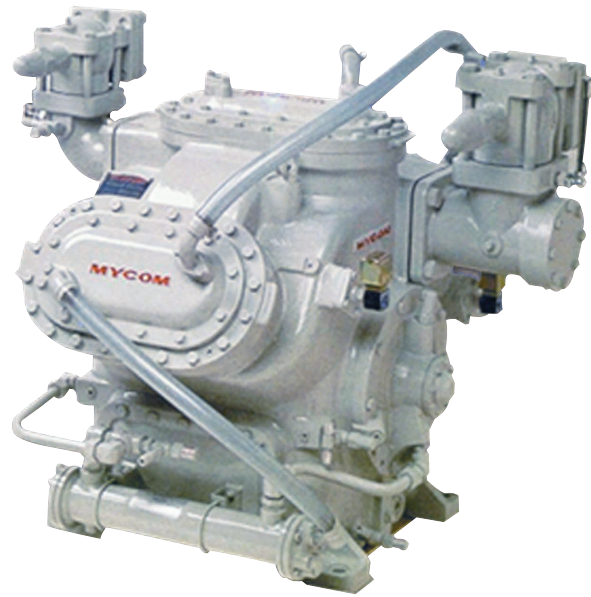

Applications

Developed for exclusive use with ammonia refrigerant, this series of compressors is suitable for refrigeration and freezing applications on land with a smaller load requirement.

Space and Weight Saving Design

A 4-pole motor can be directly connected to the compressor. Hydraulic lines for capacity control are incorporated into the casing design, allowing simplified package designs and easy maintenance.

Covers a Wide Range of Loads

Delivers powerful performance with adaptability to wide operation ranges from 1000 to 1800 rpm.

Performance charts

Ammonia

Condensing temp: 104°F Rotation speed: 970rpm
Suction superheat: 0°F Liquid Subcooling: 9°F

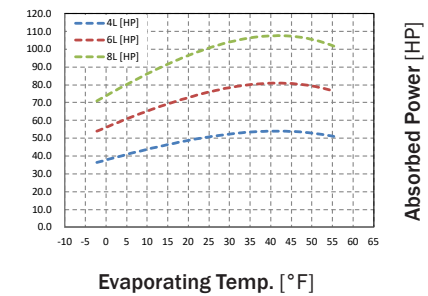
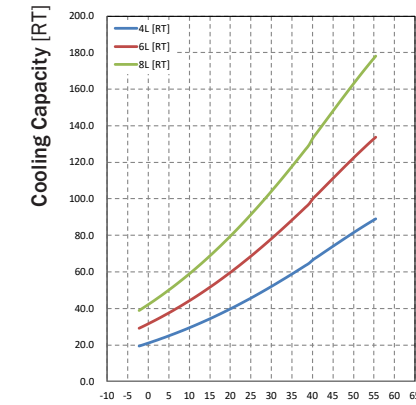

Specifications

*Some optional items are included in this photo.

Item		Model ^{*1}	4L	6L	8L
Refrigerant			Ammonia		
Compressor Type			Reciprocating, Open Type		
Number of Cylinders			4	6	8
Bore			4.5"/115mm		
Stroke			3.5"/90mm		
Displacement ^{*2}	CFM		128.3	191.9	256.0
Displacement ^{*2}	m ³ /h		218	326	435
Rotation Speed	rpm		1000-1800		
Drive Method			Direct Drive / V-belt		
Capacity Control	%		100/50	100/66/33	100/75/50/25

* 1. Specify the refrigerant by adding a prefix "N" for Ammonia to the type code. * 2. Displacement at 970 rpm.

Outer dimensions

*Please consult us for further details.

[Water cooled type (Ammonia)]

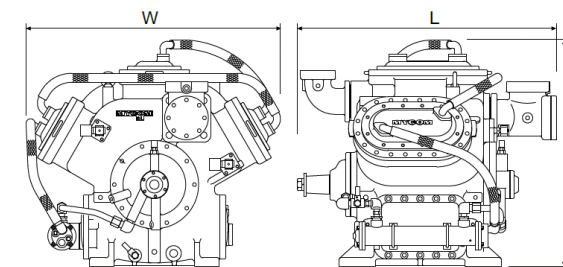

Model	Weight	W	L	H
4L	630kg	890mm	905mm	840mm
6L	750kg	1000mm	1010mm	885mm
8L	875kg	1060mm	1040mm	870mm

* The outer dimension drawings illustrate the 6-cylinder model.

* The stop valve, companion flange, flywheel, V-pulley, and safety valve are not included.

* The oil cooler is included.

MYCORE-RC100 CONTROL PANEL



MyCore-RC100

Control Panel for MYCOM reciprocating & mini-screw compressors

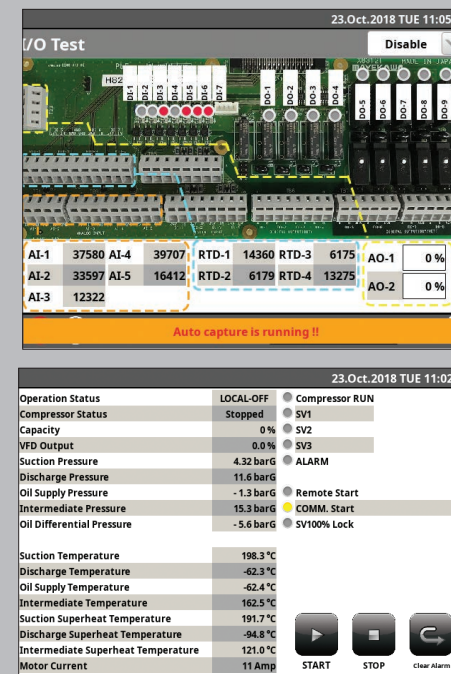

Recip Package Panel

The MyCore-RC100 is the next generation controller replacing MYPRO CP1A and MYPRO iP. This panel has controlling capabilities for MYCOM M, WA/WB, WBHE, HK, L, MHS (1290, 1410), i and other reciprocating compressors.

Standard Features

- » 5.7" resistance film type touch screen
- » Multiple languages
- » USB connection for import & export settings, data logging & screen captures
- » RS-485 communication port provides read & write data using Modbus protocol
- » Ethernet communication provides Modbus TCP/IP protocol
- » Automatic capacity control by suction pressure sensor
- » Manual operation of capacity control, and any PID controllers
- » Self-diagnosis of sensor malfunctions
- » User event function to manage changes of setting valves, and operation logs

Specifications

General Specifications

Supply Voltage	100-240 VAC 50/60 Hz
Operating Temperature	32 °F ~ 140 °F (0 °C ~ 80 °C)
Ambient Humidity	85% RH or less (non-condensing)

IO Specifications

Analog Input	Current	4~20 mA (Input Impedance 250 Ω)	Max. 5
	Voltage	1-5 VDC (Input Impedance 100k Ω)	
	Temperature	100 Ω Platinum	Max. 4
	Power	12/24 VDC	
Analog Output	Current	4~20 mA (Resistive Load 500 Ω)	Max. 2
Digital Input	Contact	PNP (24 VDC from base board)	Max. 7
Digital Input	Dry Contact	Dry N.O. contact	Max. 5
	PNP Contact	24 VDC supplied from controller	Max. 2
Digital Output	Mechanical Relay	5A at 250 VAC	Max. 4
	Solid State Relay	0.1A to 2A at 100 to 240 VAC Leakage: 1.5 mA max at 200 VAC	Max. 5

Oil Pumps MP & FP Series

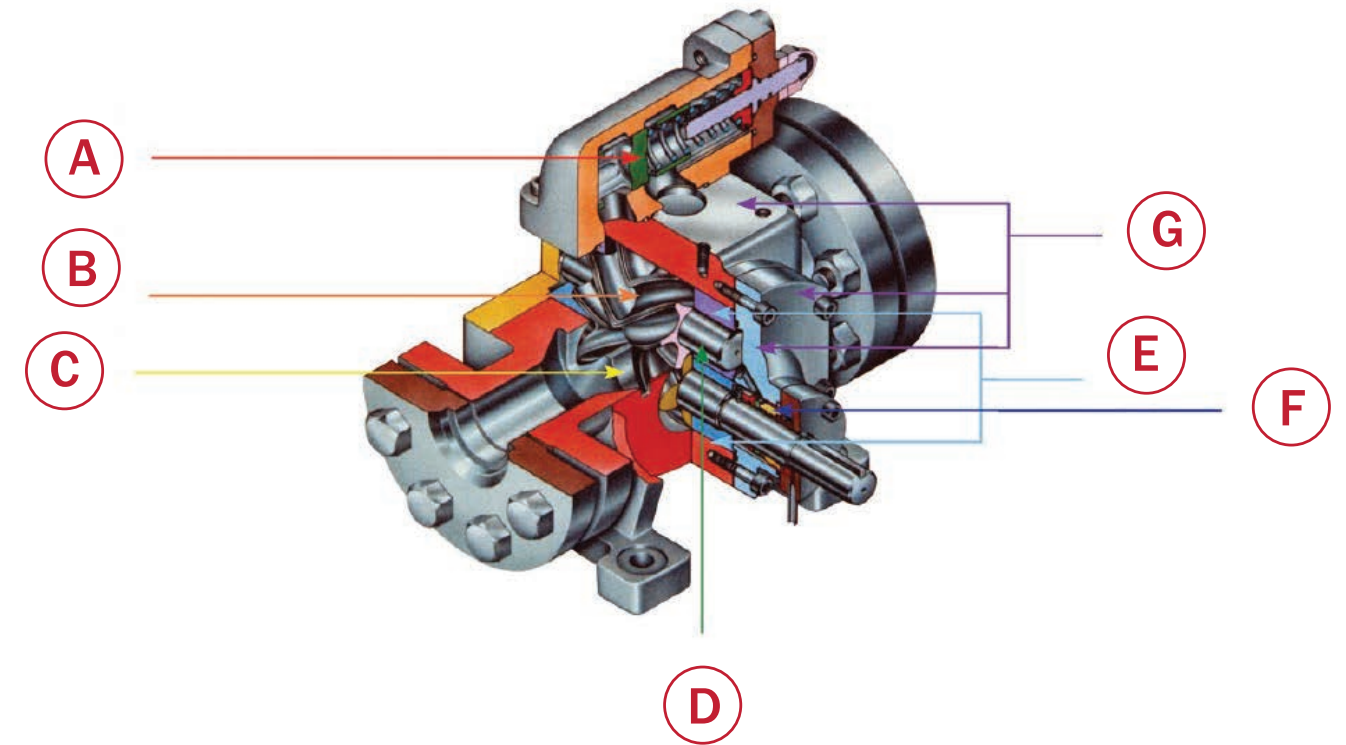

A

Integral Pressure Relief Valve

- Smooth response to the change in pressure
- High durability
- Sludge free structure
- Less noise

B

Special Rotors

- Smooth rotation due to thrust offset rotor design
- Asymmetric rotor design assures smooth contact
- High durability

C

Optimum Suction and Discharge Ports

- Optimum port design to assure smooth fluid transfer

D

Special Rotor Shaft

- Special material as well as treatment for longer life expectancy

E

Special Thrust Bearing

- Higher reliability and quality

F

High Resistance Mechanical Seal

- Balanced type structure eliminates the leakage
- Special material assures the longer resistance against the leakage
- No suction pressure to be on the seal suction

G

Casing and Cover

- Durable design and material to prevent against high pressure

OIL PUMPS

MP & FP Series
M50P/M60P/M80P/
M100P/M125P/FP50/FP60



MYCOM oil pumps are gear mesh type which employ a screw rotor design. They are suitable for screw compressor lubrication systems.

Longer life

Industry-proven durability with no thrust load screw gear structure

Low noise, low vibration

With integral pressure-regulating valve which creates an uncomplicated lube system (the relief valve can cover up to 50% of the total flow).

Open type (MP series) and C-flange type (FP series) are available.

Specifications *Standard Line-up

Model	M50P	M60P	M80P	M100P	M125P	FP50	FP60	
Maximum Speed [rpm]	1750	1750	1750	1450	1150	1750	1750	
Minimum Speed [rpm]	950	950	720	720	720	950	950	
Rotation *1	CW	CW	CW	CCW	CCW	CCW	CCW	
Std Flow Direction *1	R → L	R → L	R → L	R → L	R → L	R → L	R → L	
Capacity @50CST [GPM]	17-33	35-68	76-138	112-224	225-357	17-33	35-68	
Design Pressure [psig]	377	377	377	377	377	377	377	
Max. Outlet Pressure [psig]	362	319	362	362	362	319	319	
Min. Inlet Pressure [psig]	-4.3							
Differential Pressure	with Relief Valve							Max. 58 psi
	w/o Relief Valve							Max. 290 psi
Max. Inlet Temperature [F] *2	176							
Viscosity of Fluid [cst]	3 - 500							
Oil Strainer Before Pump	≥ 150 μm							

* 1. Reverse rotation and reverse flow direction is available upon request.
* 2. Higher temperature is available up to 266 deg. F.

Specifications *Special Line-up

Model	M50PH	M60PH	M80PH	M100PH	M125PH
Design Pressure [psig]	435	N/A	435	435	435
Max. Outlet Pressure [psig] *3	435	N/A	435	435	435
Max. Outlet Pressure [psig] *4	435	N/A	435	435	N/A
Max. Inlet Temperature [F]	266				

* 3. Cast iron casing with tandem shaft
* 4. Cast steel casing with tandem shaft. This pump has ANSI#300 flanges available.
** All other items are the same as the standard.

Outer dimensions

F50P / F60P

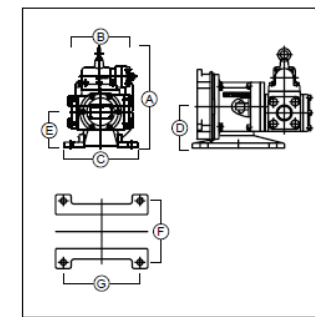

M50P / M60P

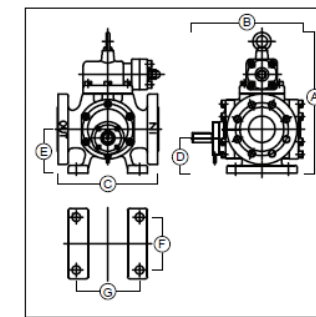

M80P

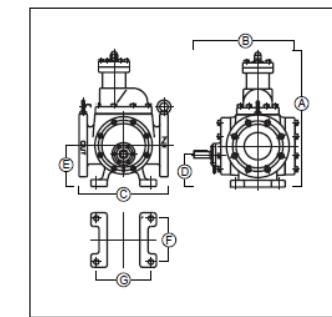

M100P

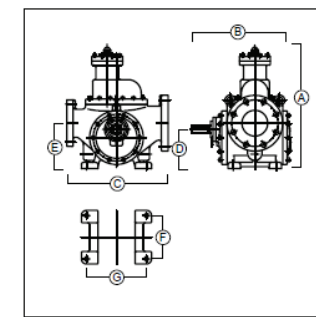

M125P

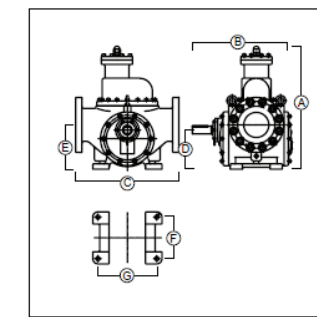

Model	A	B	C	D	E	F	G
F50P/F60P	13"/335mm	24"/601mm	6"/150mm	6"/145mm	5"/125mm	7"/170mm	9"/220mm
M50P	13"/320mm	10"/251mm	9"/230mm	3"/80mm	4"/100mm	5"/120mm	6"/144mm
M60P	13"/330mm	12"/295mm	9"/230mm	3"/80mm	4"/100mm	5"/120mm	6"/144mm
M80P	20"/495mm	15"/382mm	13"/330mm	5"/118mm	6"/150mm	7"/160mm	8"/200mm
M100P	23"/588mm	19"/476mm	20"/490mm	8"/190mm	9"/220mm	9"/210mm	12"/290mm
M125P	28"/709mm	23"/578mm	24"/600mm	9"/225mm	10"/255mm	10"/240mm	14"/340mm

Measurements are in mm [inches].

* Information shown here is for reference only. Subject to change without notice. Please contact Mayekawa for details.

Genuine OEM

MANUFACTURED PARTS

MYCOM's genuine OEM parts are designed to ensure the longevity of your MYCOM Compressor. A long lasting product paired with a great warranty equals more money in your pocket. To buy MYCOM OEM parts, contact a Mayekawa office or contact the sales representative in your area. You can find a list of sales representatives by location at:

https://mayekawa.com/americas/mna/company/sales_representatives



To purchase MYCOM Genuine OEM parts, call a sales rep in your area, contact one of the Mayekawa offices listed below or send an email to info@mayekawausa.com.

SALES REPRESENTATIVES

Sales Rep	Phone Number	Address	Territory
Clark Johnson Company, Inc.	714-521-6161	14747 Artesia Blvd, 2-E La mirada, CA 90638	Arizona, California, Nevada, Utah
Freeze-Pro, Inc.	904-531-5065	3516 Enterprise Way, Suite 3, Green Cover Springs, FL 32043	Alabama, Florida, Georgia
Stanton & Associates, Inc.	574-247-5522	6910 N. Main Street, Unit 15 Granger, IN 46530	Iowa, Illinois, Indiana, Kentucky, Michigan, Minnesota, Nebraska, North Dakota, Ohio, South Dakota, Wisconsin
IREP	206-941-8095 604-219-6049	1540 NE 95th Street Seattle, WA 98115	Colorado, Idaho, Montana, Oregon, Washington, Wyoming
Industrial Refrigeration Sales, LLC.	210-314-8733	8000 Fair Oaks Pkwy Suite 3117 Boerne, TX 78015	Arkansas, Kansas, Louisiana, Missouri, Mississippi, New Mexico, Oklahoma, Tennessee, Texas
Refrigeration Technology Solutions	803-717-2717	PO Box 38145 Albany, NY 12203	Connecticut, Delaware, District of Columbia (Washington DC), Massachusetts, Maryland, Maine, North Carolina, New Hampshire, New Jersey, New York, Pennsylvania, Rhode Island, South Carolina, Virginia, Vermont, West Virginia
Refrielectrica Popa	809-271-5507	C/ Rubén Dario No. 25, Ens. Enriquillo, Herrera, Santo Domingo Oeste, R.D.	Dominican Republic

MAYEKAWA USA OFFICES FOR PARTS SALES

York

3395 Farmtrail Rd.
York, PA 17406
717-779-0138

Torrance

19240 Van Ness Ave.
Torrance, CA 90501
310-328-1362